

# Flying and Judging F3A

---

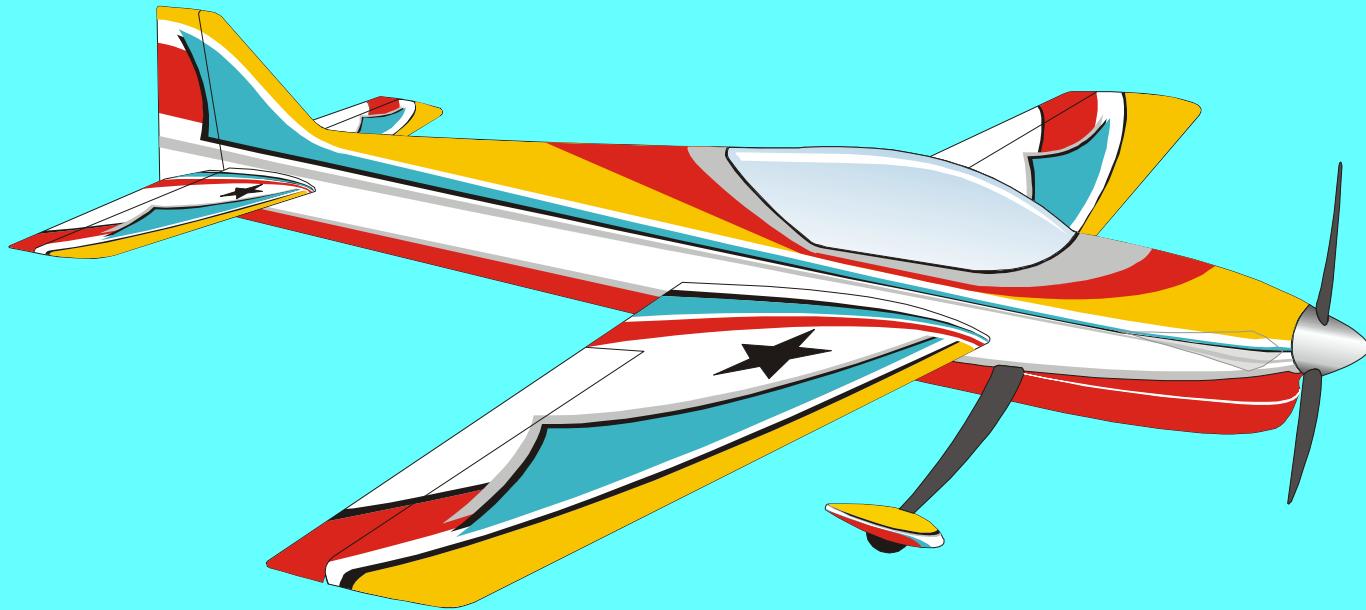

---

**SCHEMATIC MANOEUVRE ILLUSTRATIONS**  
**SCHEDULE P-19**

# PRELIMINARY SCHEDULE P-19 (2018-2019)

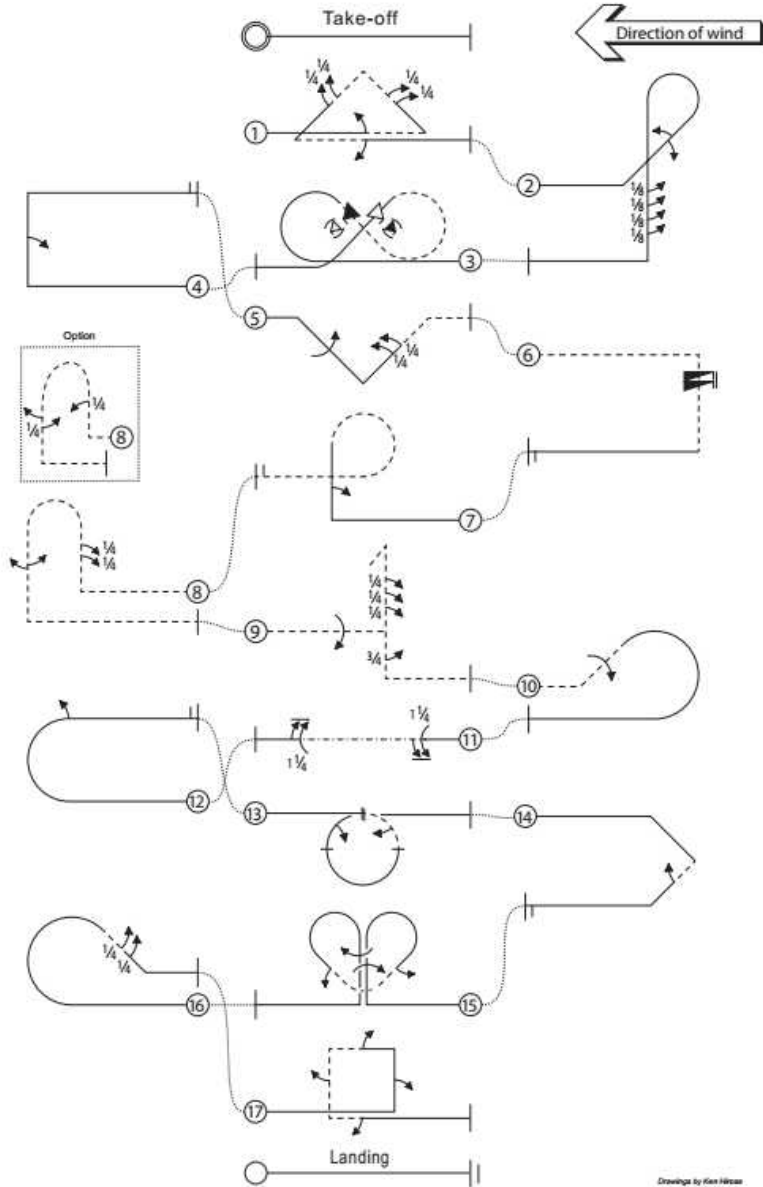

Drawings by Ken Hince  
Oct. 2014

# PRELIMINARY SCHEDULE P-19 (2018-2019)

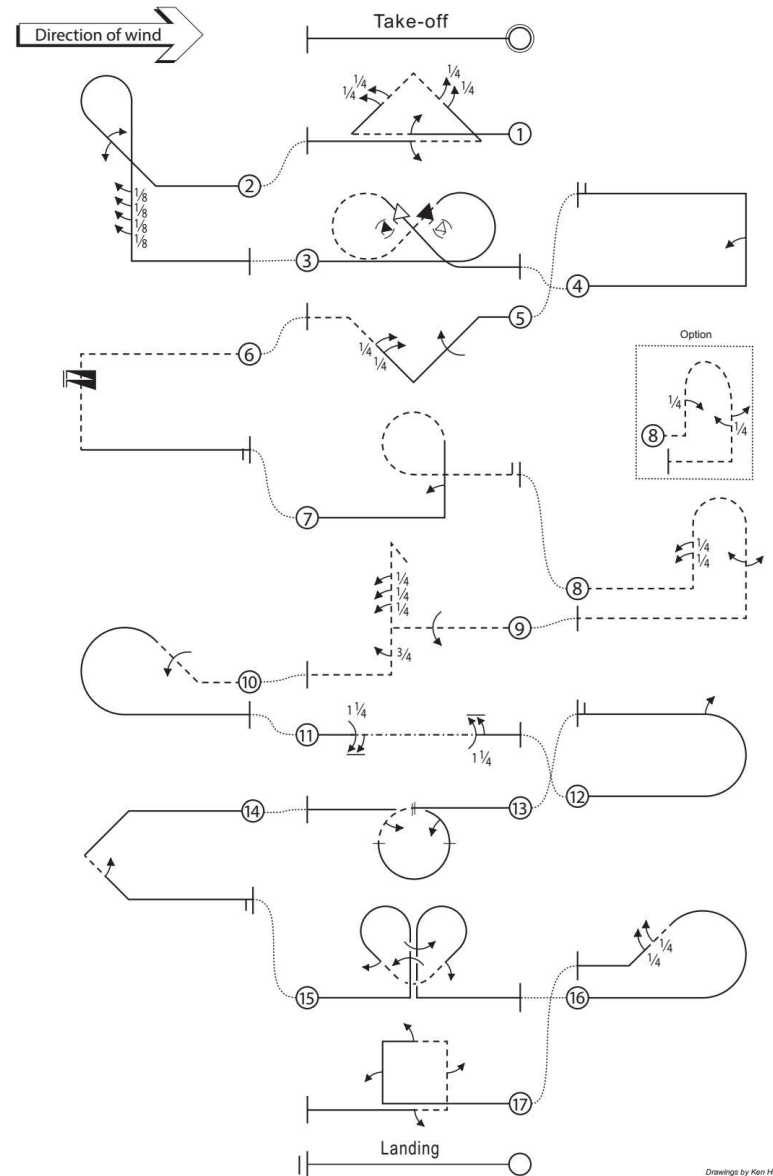

Drawings by Ken Hince  
Oct. 2014



# Take-off procedure ( not judged, not scored )

← wind

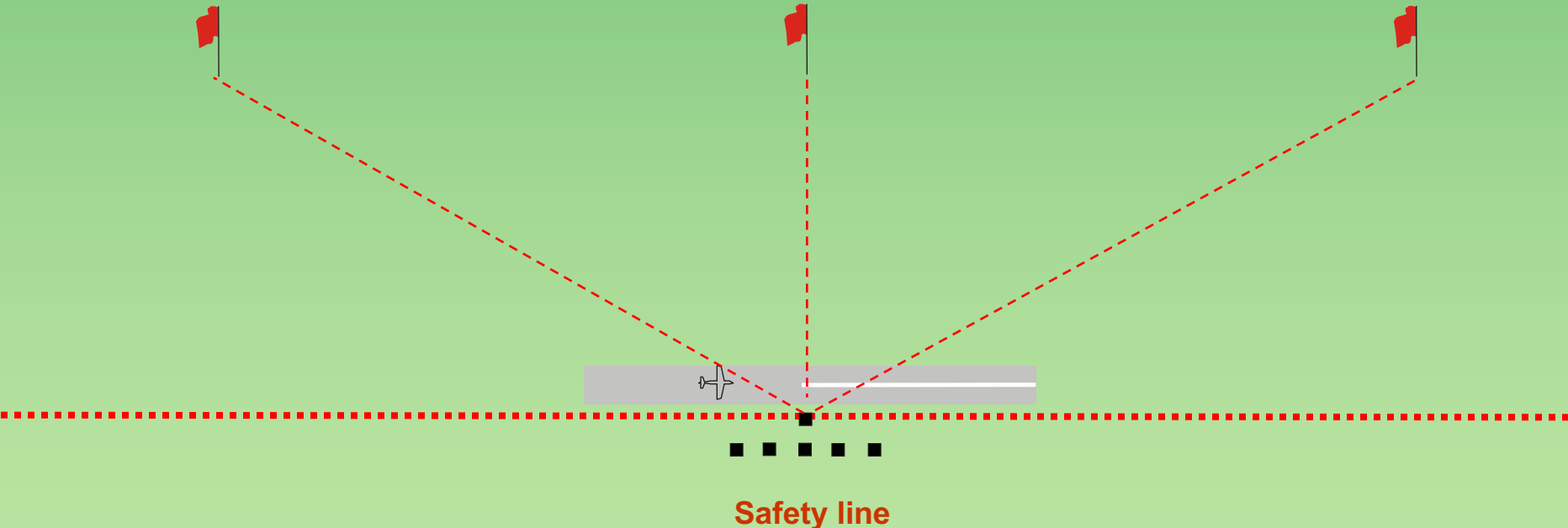



# P-19.01 Triangle loop with $\frac{1}{2}$ roll, consecutive two $\frac{1}{4}$ rolls, consecutive two $\frac{1}{4}$ rolls, $\frac{1}{2}$ roll

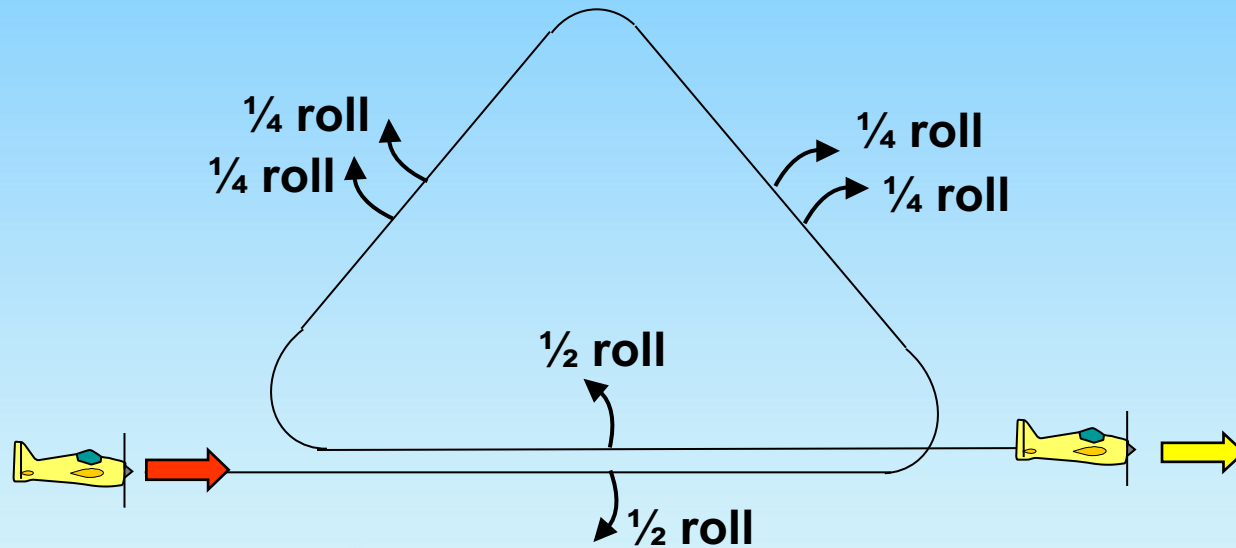

From upright, perform a  $\frac{1}{2}$  roll in the centre, push through a  $\frac{3}{8}$  loop into a  $45^\circ$  upline, perform consecutively two  $\frac{1}{4}$  rolls, pull through  $\frac{1}{4}$  loop into a  $45^\circ$  downline, perform consecutively two  $\frac{1}{4}$  rolls, push through a  $\frac{3}{8}$  loop, perform a  $\frac{1}{2}$  roll in the centre, exit upright.



# P-19.01 Triangle loop with $\frac{1}{2}$ roll, consecutive two $\frac{1}{4}$ rolls, consecutive two $\frac{1}{4}$ rolls, $\frac{1}{2}$ roll

All radii are equal.

Lines between part rolls must be short and of recognizable length.

$\frac{1}{4}$  rolls centered on middle of the lines.

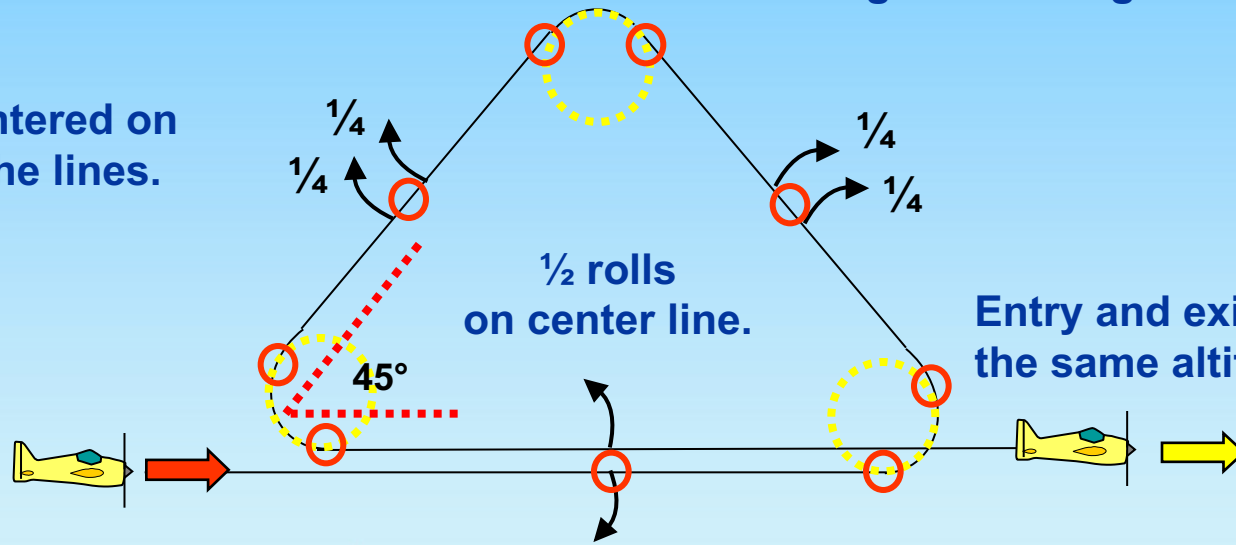

Entry and exit must be at the same altitude.





## P-19.02 Figure Et with consecutive two $\frac{1}{2}$ rolls in opposite directions, consecutive four $\frac{1}{8}$ rolls

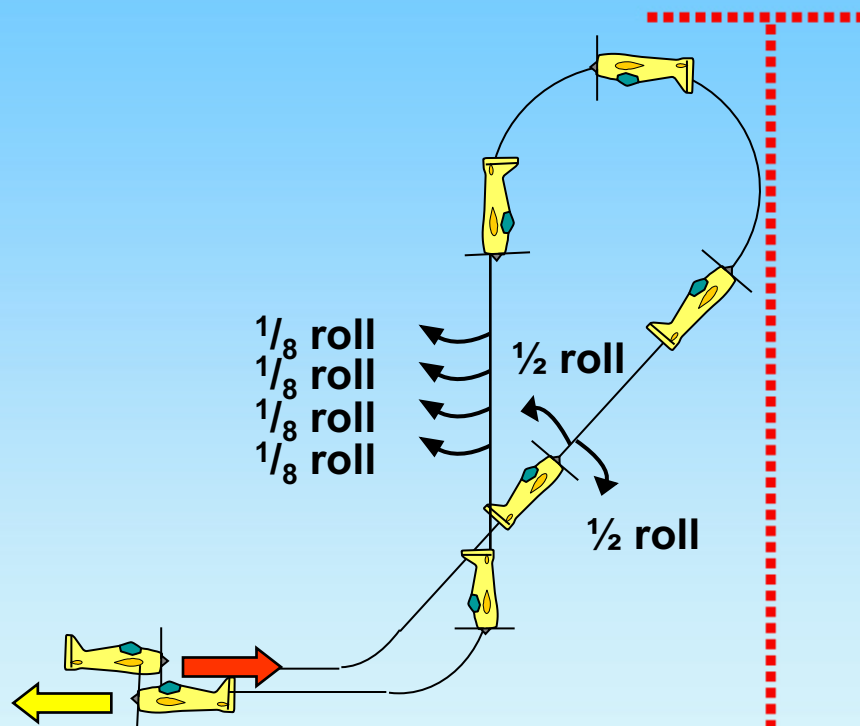

From upright, pull through a  $\frac{1}{8}$  loop into a  $45^\circ$  upline, perform consecutively two  $\frac{1}{2}$  rolls in opposite directions pull through a  $\frac{5}{8}$  loop into a vertical downline, perform consecutively four  $\frac{1}{8}$  rolls, pull through a  $\frac{1}{4}$  loop, exit upright.



# P-19.02 Figure Et with consecutive two $\frac{1}{2}$ rolls in opposite directions, consecutive four $\frac{1}{8}$ rolls

All radii are equal.

$\frac{1}{2}$  rolls and  $\frac{1}{8}$  rolls centered on middle of the lines.

Lines between part rolls must be short and of equal length.

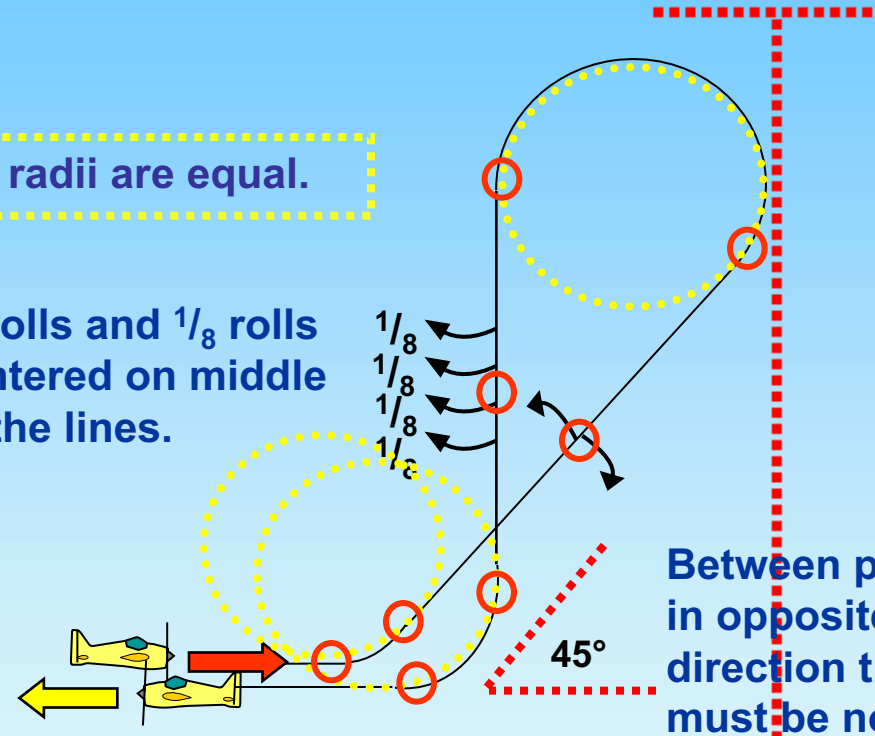

Between part rolls in opposite direction there must be no line.

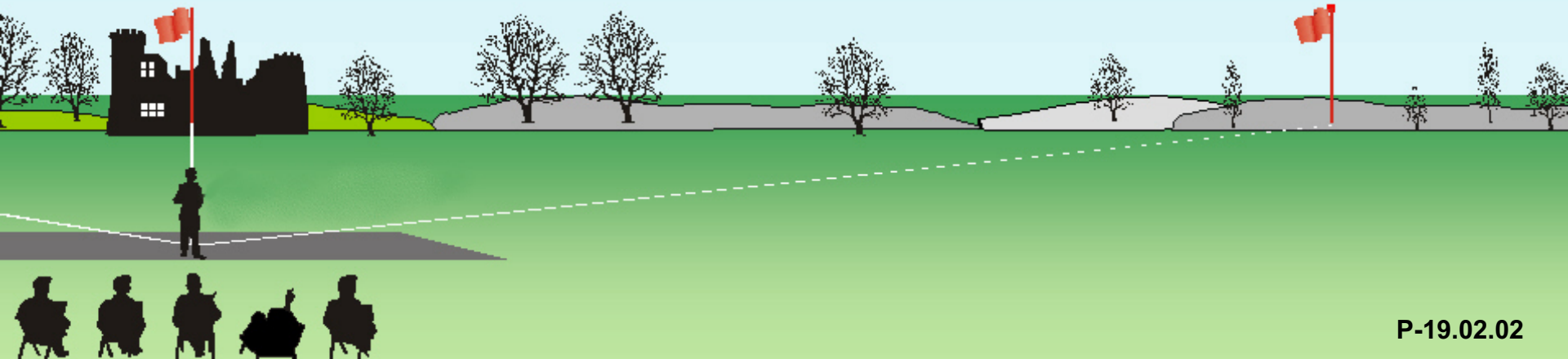



## P-19.03 Cuban 8 with snap-roll, snap-roll

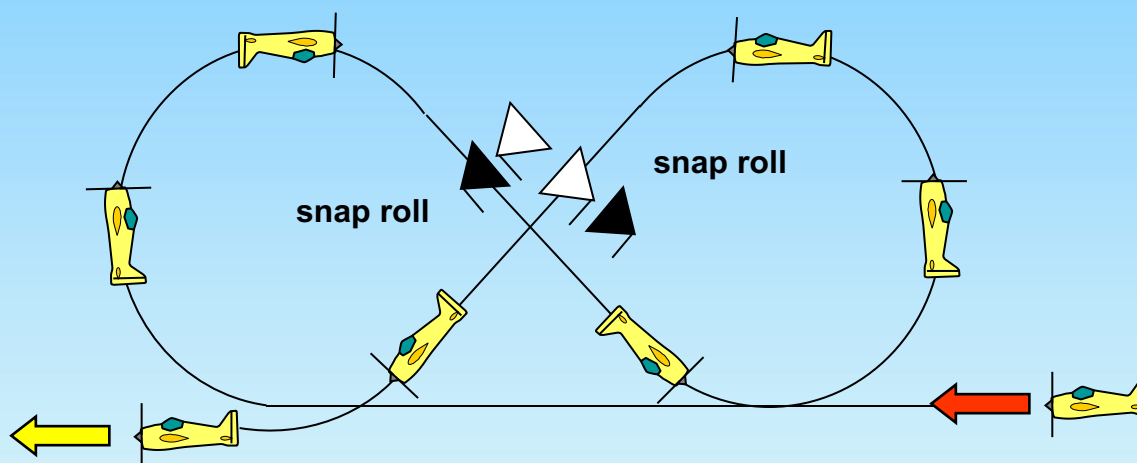

From upright, pull through a 5/8 loop into a 45° downline, perform a snap-roll, push through a 3/4 loop into a 45° downline, perform a snap-roll pull through a 1/8 loop, exit upright.







# P-19.03 Cuban 8 with snap-roll, snap-roll

If snap roll = barrel roll or aileron roll:  
**Severe downgrade > 5 pts.**

Snap rolls on middle of the lines.

Snap rolls may be positive or negative.

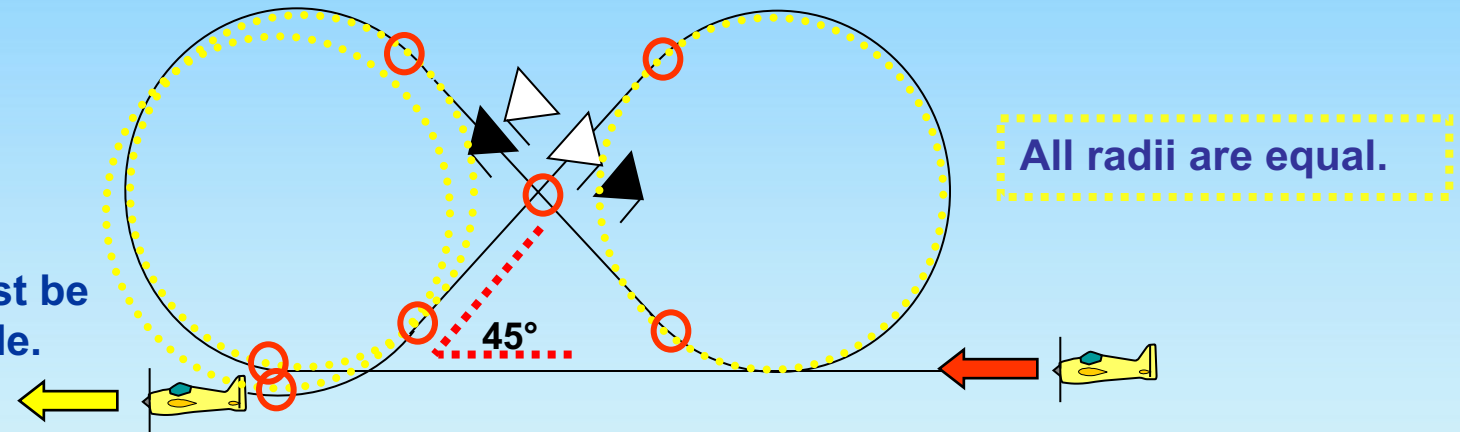

Entry and exit must be at the same altitude.



# P-19.04 Half square loop with 1/2 roll

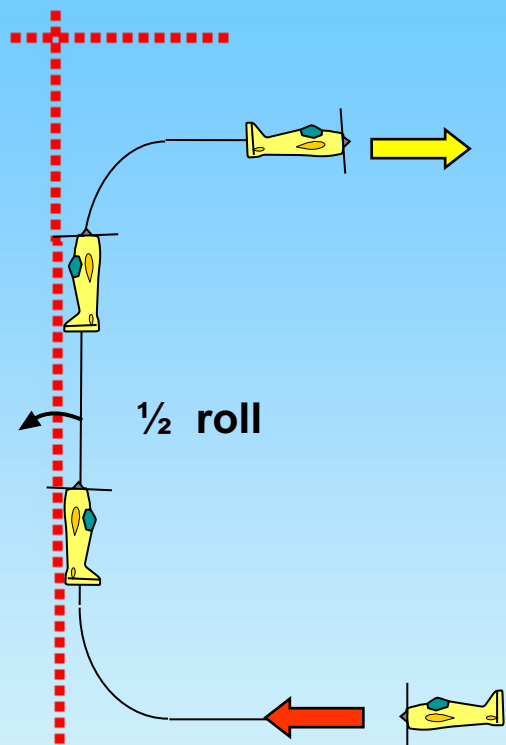

**From upright, pull through a 1/4 loop into a vertical upline, perform a 1/2 roll, push through a 1/4 loop, exit upright.**



# P-19.04 Half square loop with 1/2 roll

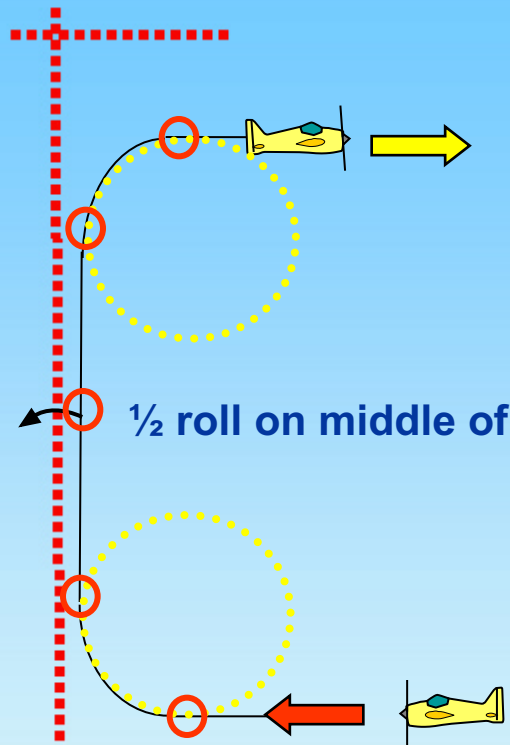

All radii are equal.

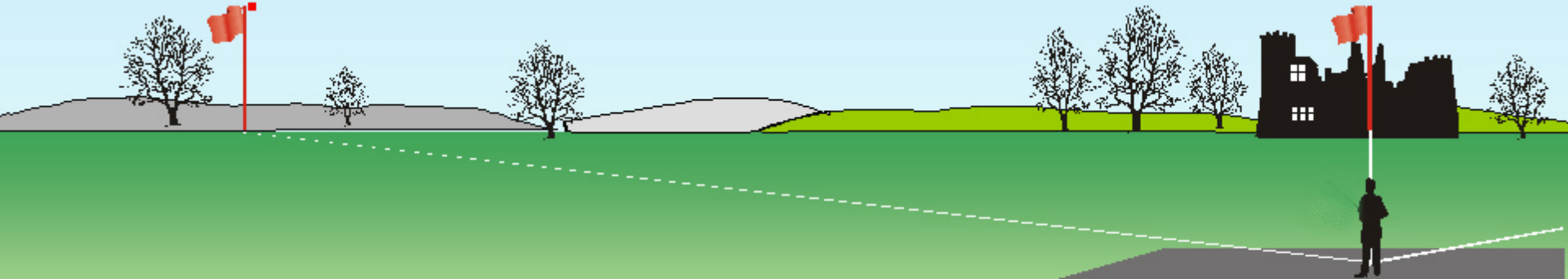



# P-19.05 Reverse Cobra Roll with roll, consecutive two $\frac{1}{4}$ rolls

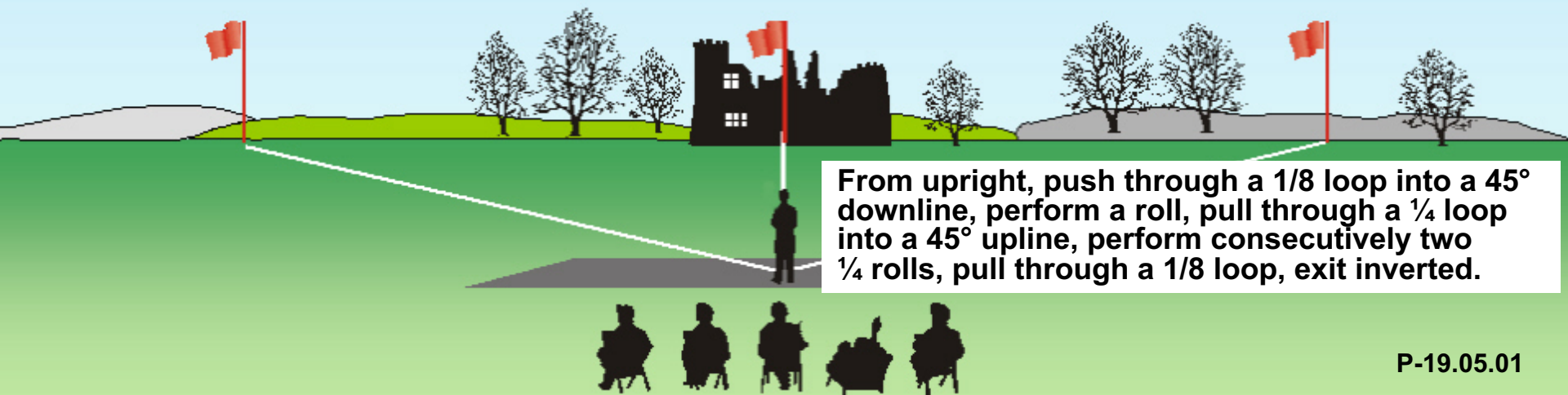
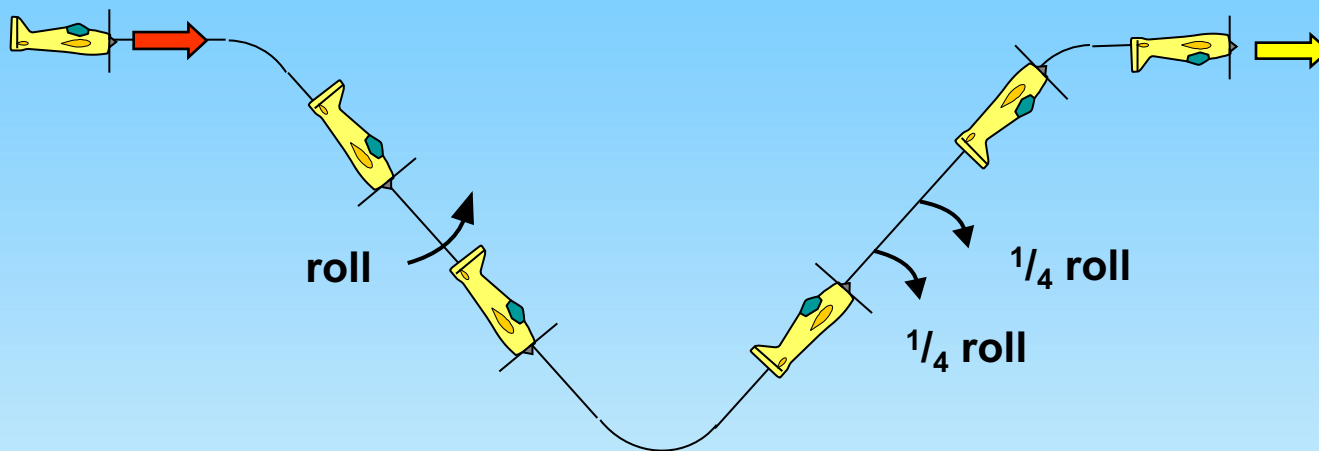

From upright, push through a  $\frac{1}{8}$  loop into a  $45^\circ$  downline, perform a roll, pull through a  $\frac{1}{4}$  loop into a  $45^\circ$  upline, perform consecutively two  $\frac{1}{4}$  rolls, pull through a  $\frac{1}{8}$  loop, exit inverted.

# P-19.05 Reverse Cobra Roll with roll, consecutive two 1/4 rolls

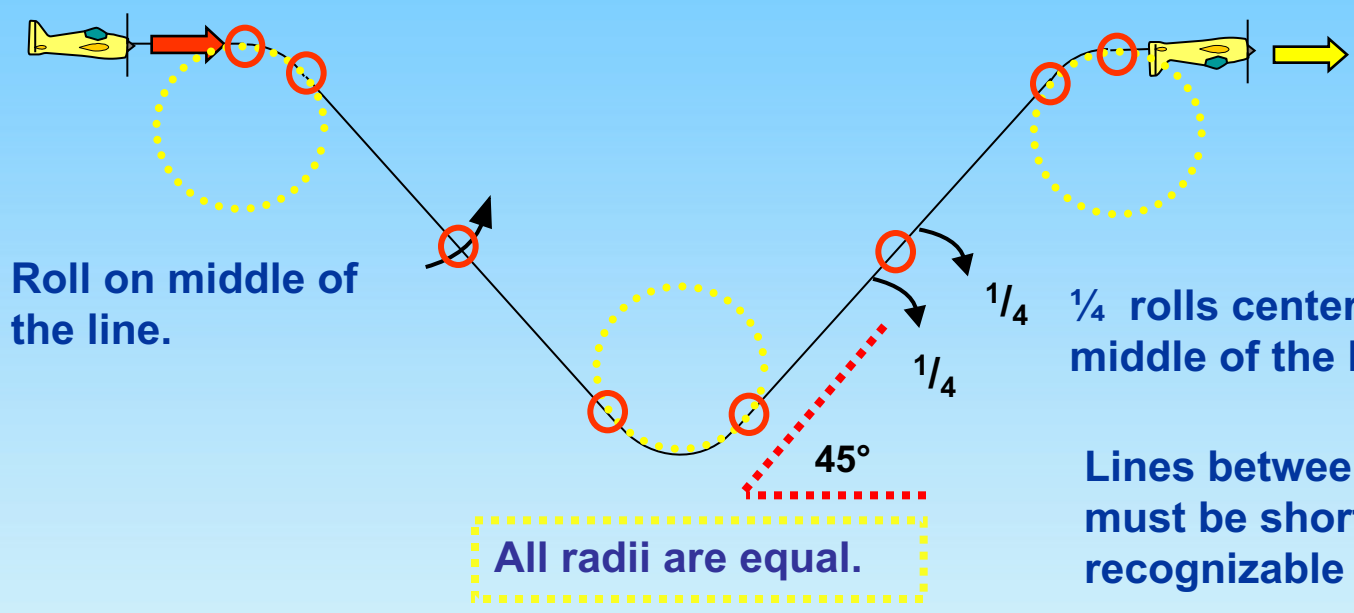

Roll on middle of the line.

1/4 rolls centered on middle of the line.

All radii are equal.

Lines between part rolls must be short and of recognizable length.





## P-19.06 Inverted Spin with two turns

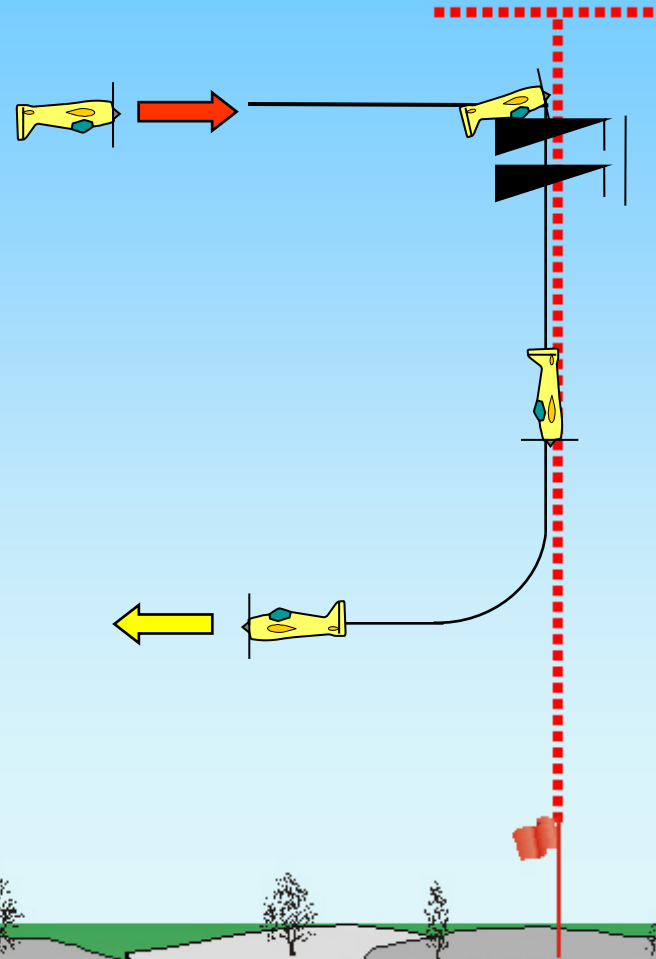

From inverted, perform an inverted spin with two turns, perform a vertical downline, pull through a  $\frac{1}{4}$  loop, exit upright.



# P-19.06 Inverted Spin with two turns

Snap entry - **zero points!**

Spiral dive - **zero points!**

Forced entry- **downgrade.**

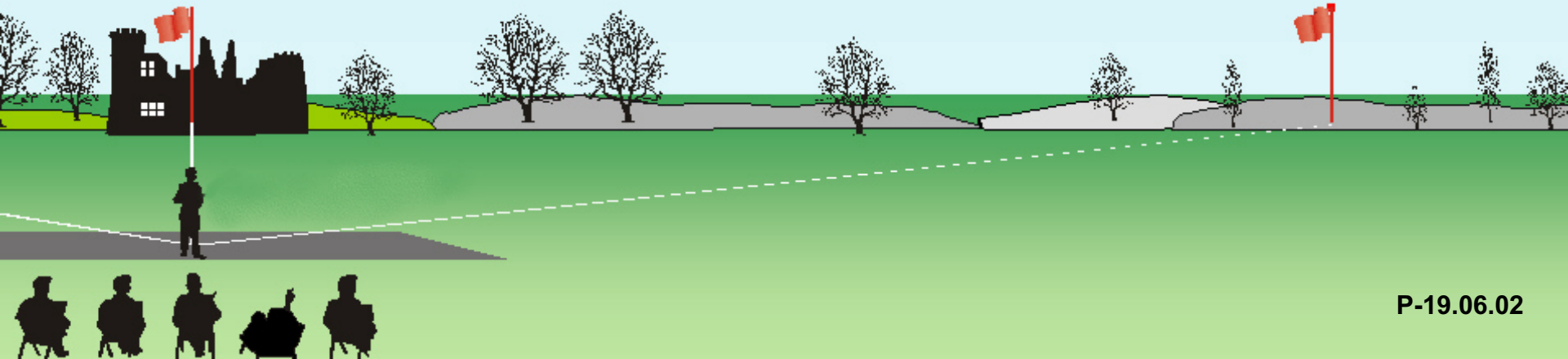
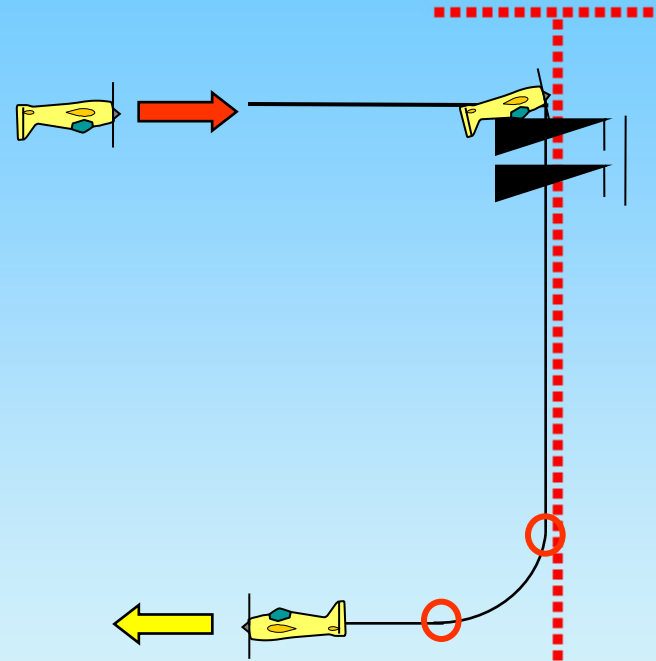

# P-19.07 Figure 9 with 1/2 roll

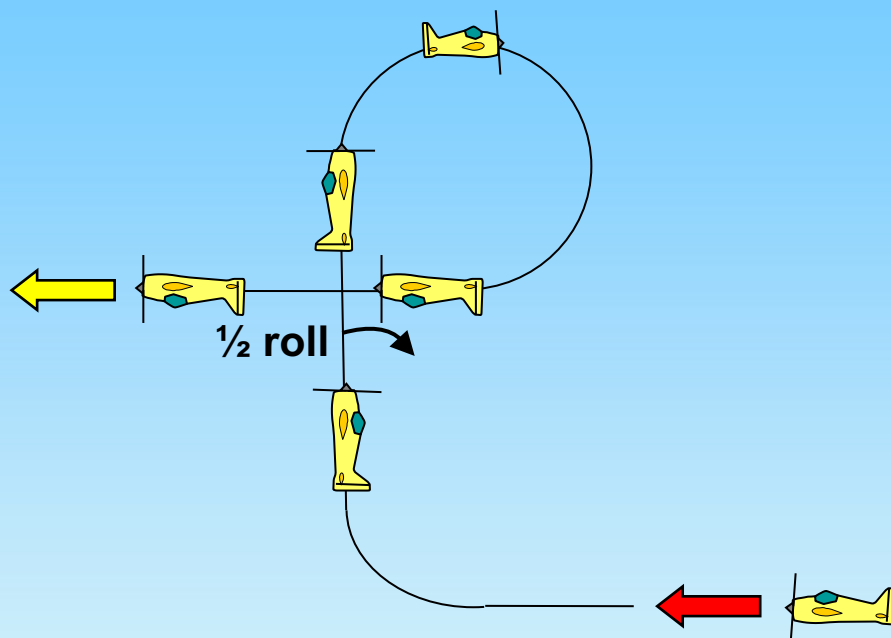

From upright, pull through a  $\frac{1}{4}$  loop into a vertical upline, perform a  $\frac{1}{2}$  roll, push through a  $\frac{3}{4}$  loop, exit inverted.



# P-19.07 Figure 9 with 1/2 roll

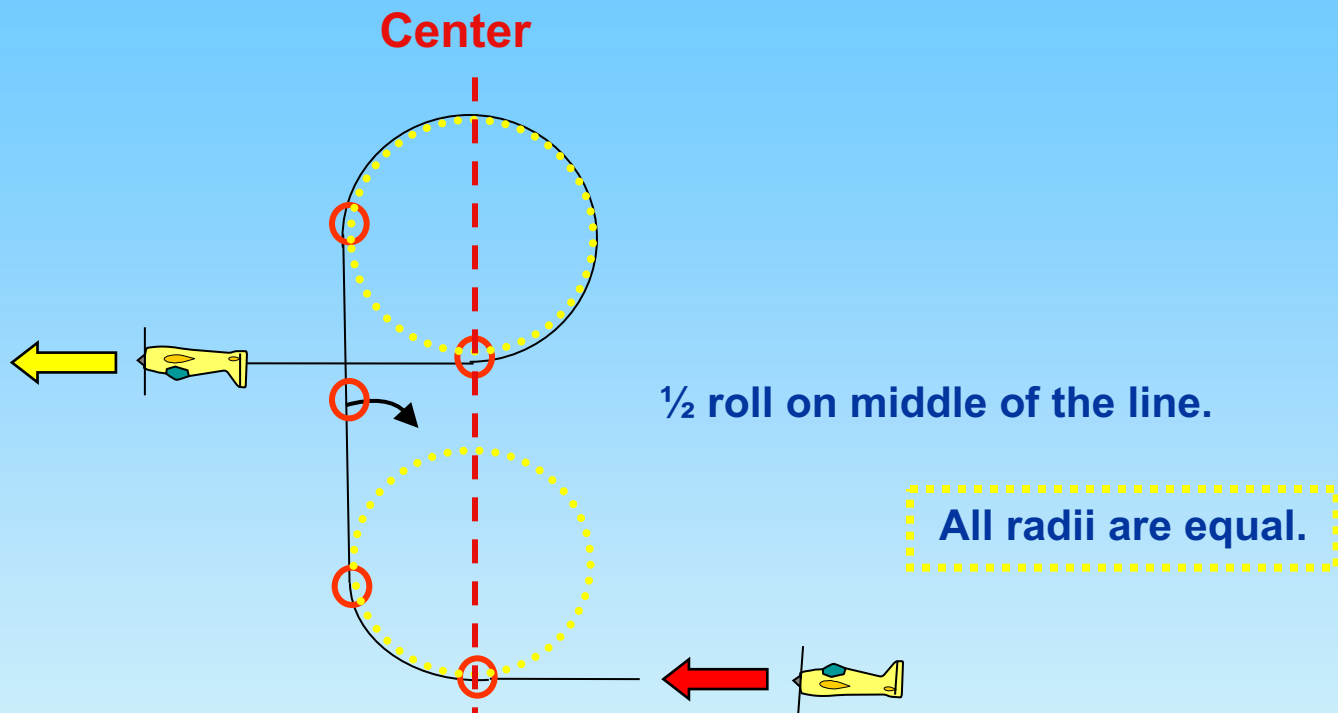

# P-19.08 Push-Push-Push Humpty-Bump with consecutive two $\frac{1}{4}$ rolls, consecutive two $\frac{1}{2}$ rolls in opposite directions (Option: with $\frac{1}{4}$ roll, consecutive $\frac{1}{2}$ roll, $\frac{1}{4}$ roll in opposite directions)

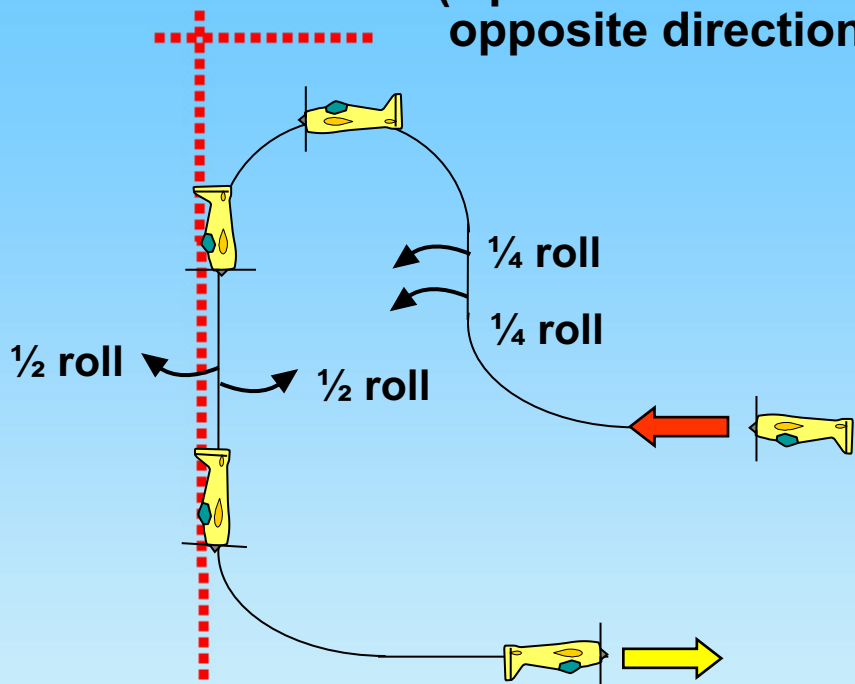

From inverted, push through a  $\frac{1}{4}$  loop into a vertical upline, perform consecutively two  $\frac{1}{4}$  rolls, push through a  $\frac{1}{2}$  loop into a vertical downline, perform consecutively two  $\frac{1}{2}$  rolls, in opposite directions, push through a  $\frac{1}{4}$  loop, exit inverted.



# P-19.08 Push-Push-Push Humpty-Bump with consecutive two $\frac{1}{4}$ rolls, consecutive two $\frac{1}{2}$ rolls in opposite directions (Option: with $\frac{1}{4}$ roll, consecutive $\frac{1}{2}$ roll, $\frac{1}{4}$ roll in opposite directions)

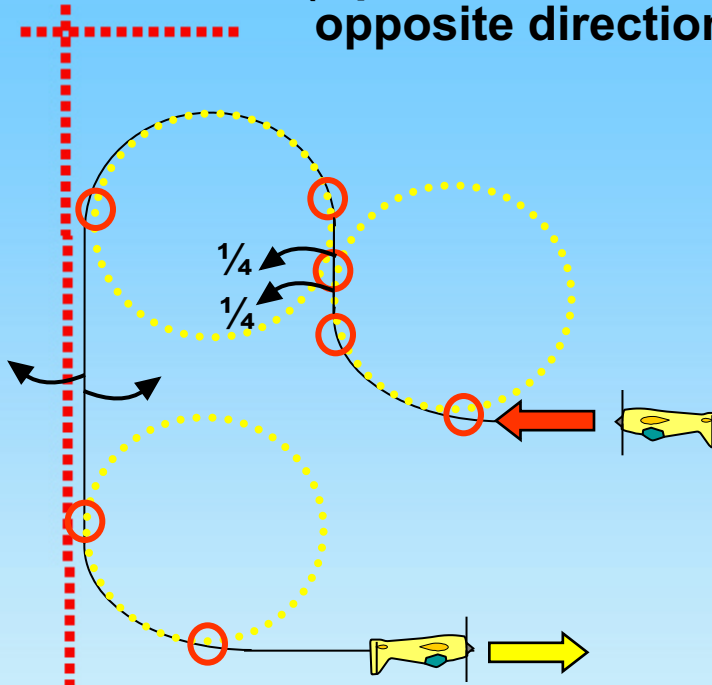

$\frac{1}{4}$  rolls and  $\frac{1}{2}$  rolls centered on middle of the line.

Lines between part rolls must be short and of recognizable length.

Between rolls in opposite direction there must be no line.

All radii are equal.

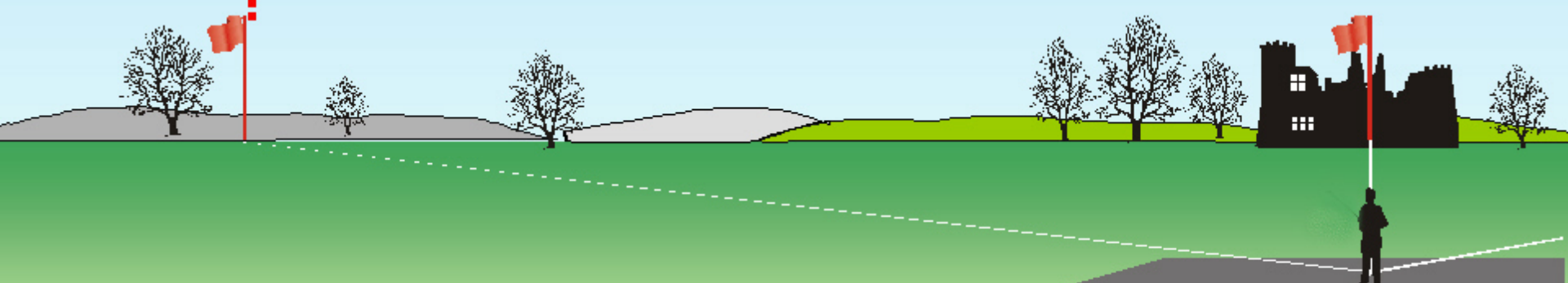

**P-19.08 Push-Push-Push Humpty-Bump with consecutive two  $\frac{1}{4}$  rolls, consecutive two  $\frac{1}{2}$  rolls in opposite directions (Option: with  $\frac{1}{4}$  roll, consecutive  $\frac{1}{2}$  roll,  $\frac{1}{4}$  roll in opposite directions)**

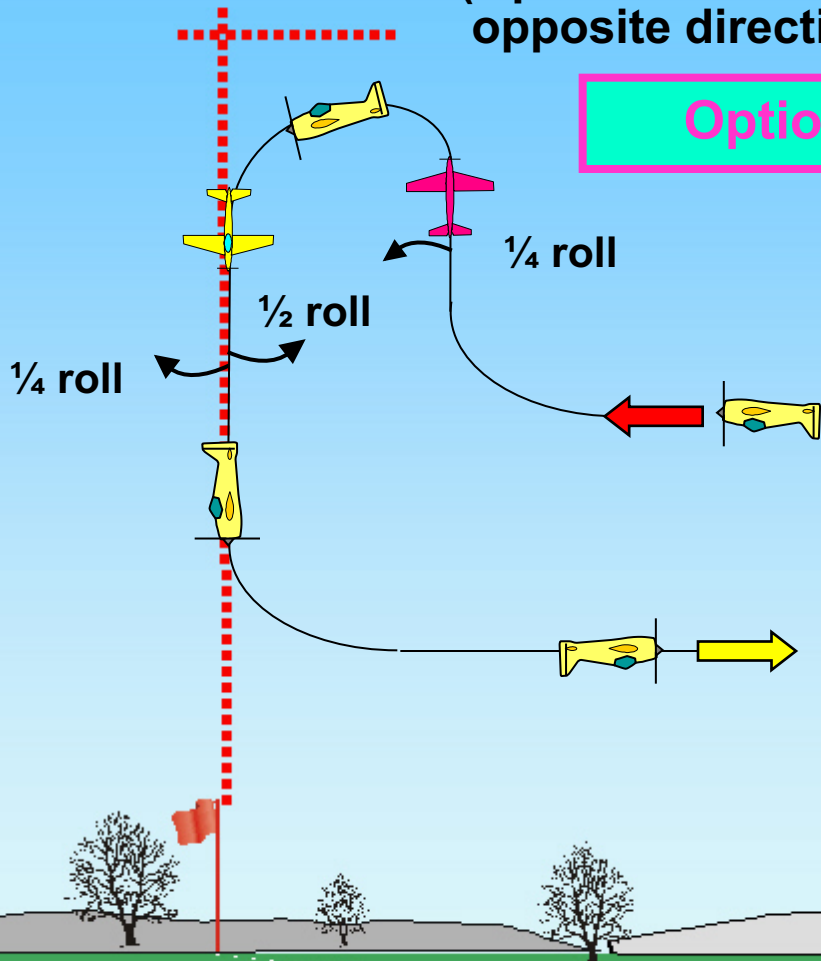

**Option: From inverted, push through a  $\frac{1}{4}$  loop into a vertical upline, perform a  $\frac{1}{4}$  roll, push through a  $\frac{1}{2}$  loop into a vertical downline, perform consecutively a  $\frac{1}{2}$  roll,  $\frac{1}{4}$  roll in opposite directions, push through a  $\frac{1}{4}$  loop, exit inverted.**

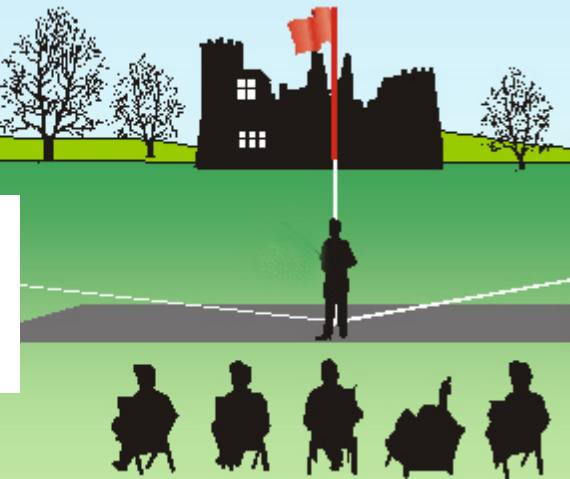



**P-19.08 Push-Push-Push Humpty-Bump with consecutive two  $\frac{1}{4}$  rolls, consecutive two  $\frac{1}{2}$  rolls in opposite directions (Option: with  $\frac{1}{4}$  roll, consecutive  $\frac{1}{2}$  roll,  $\frac{1}{4}$  roll in opposite directions)**

**Option**

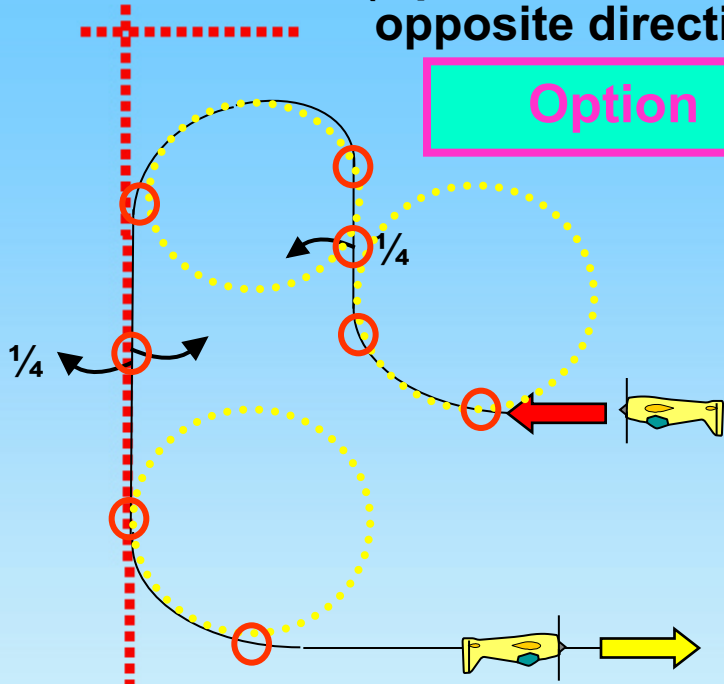

All part rolls centered on middle of the lines.

Between rolls in opposite direction there must be no line.

All radii are equal.

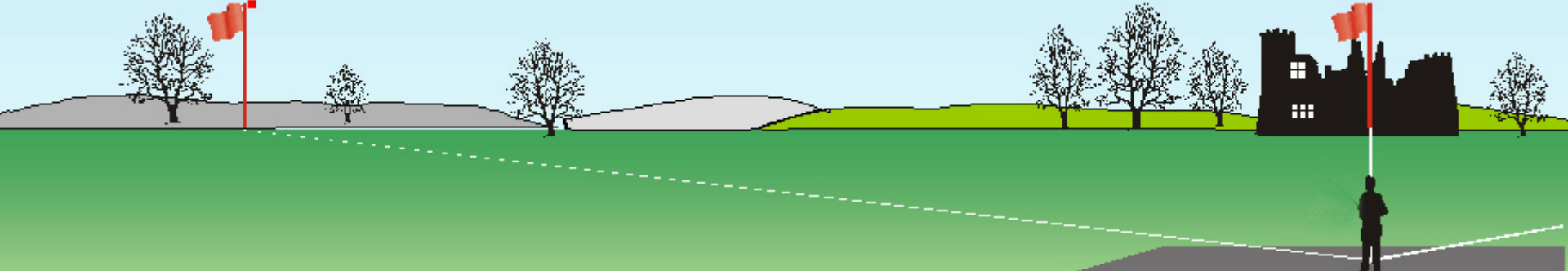



# P-19.09 Stall Turn with roll, consecutive three $\frac{1}{4}$ rolls, $\frac{3}{4}$ roll

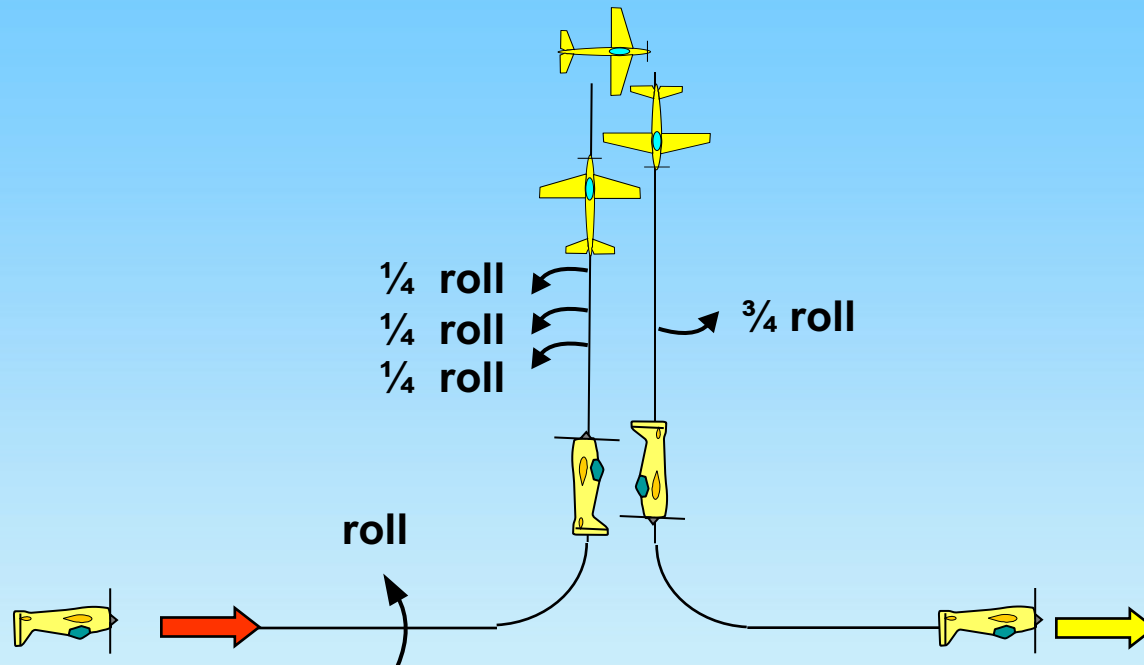

From Inverted, perform a roll, push through a  $\frac{1}{4}$  loop into a vertical upline, perform consecutively three  $\frac{1}{4}$  rolls, perform a stall turn into a vertical downline, perform a  $\frac{3}{4}$  roll, push through a  $\frac{1}{4}$  loop, exit inverted.

# P-19.09 Stall Turn with roll, consecutive three 1/4 rolls, 3/4 roll

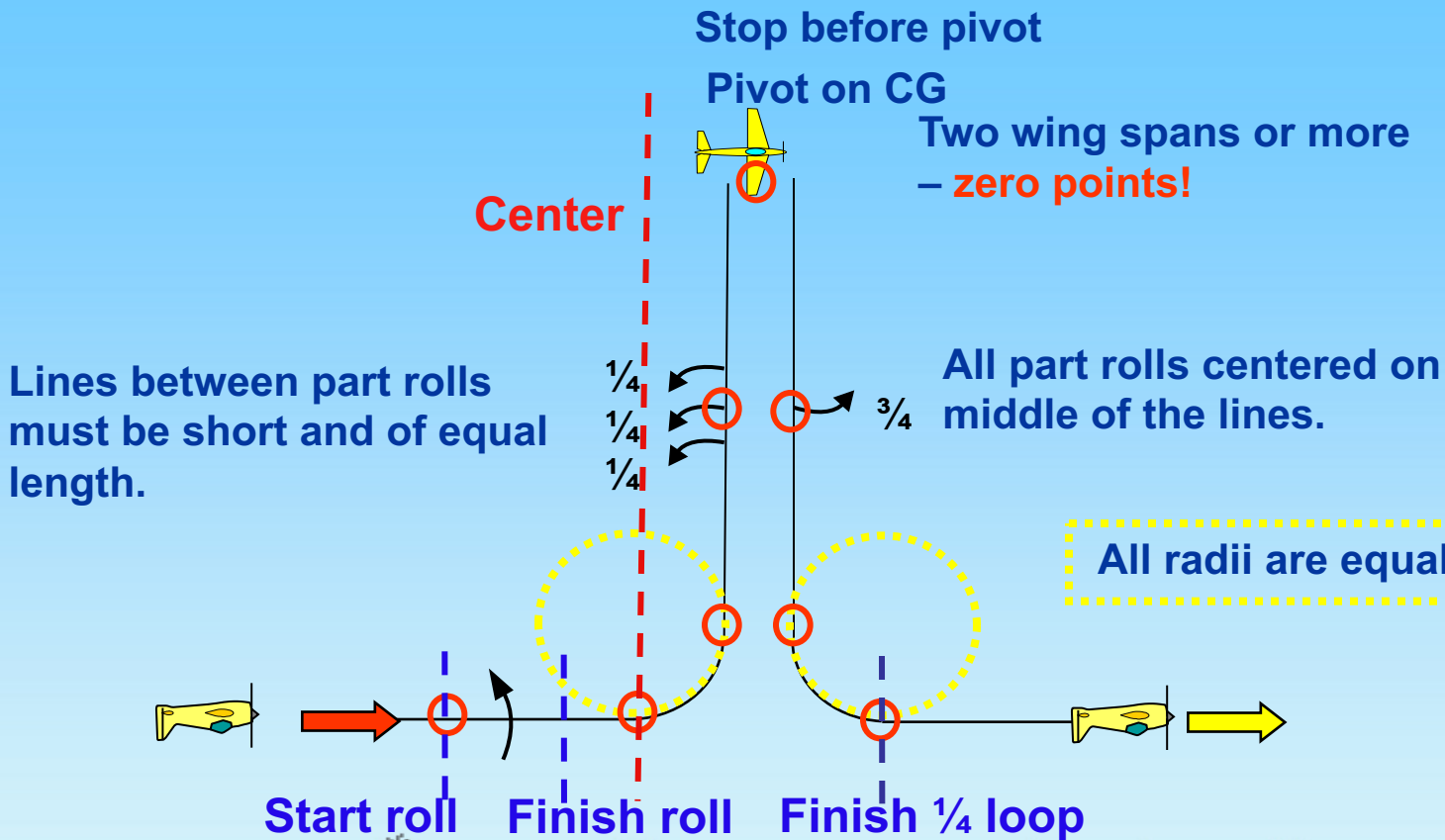

The position of the Stall Turn depends on the length of the roll.  
After the roll there must be a short line.

# P-19.10 Half Reverse Cuban 8 with roll

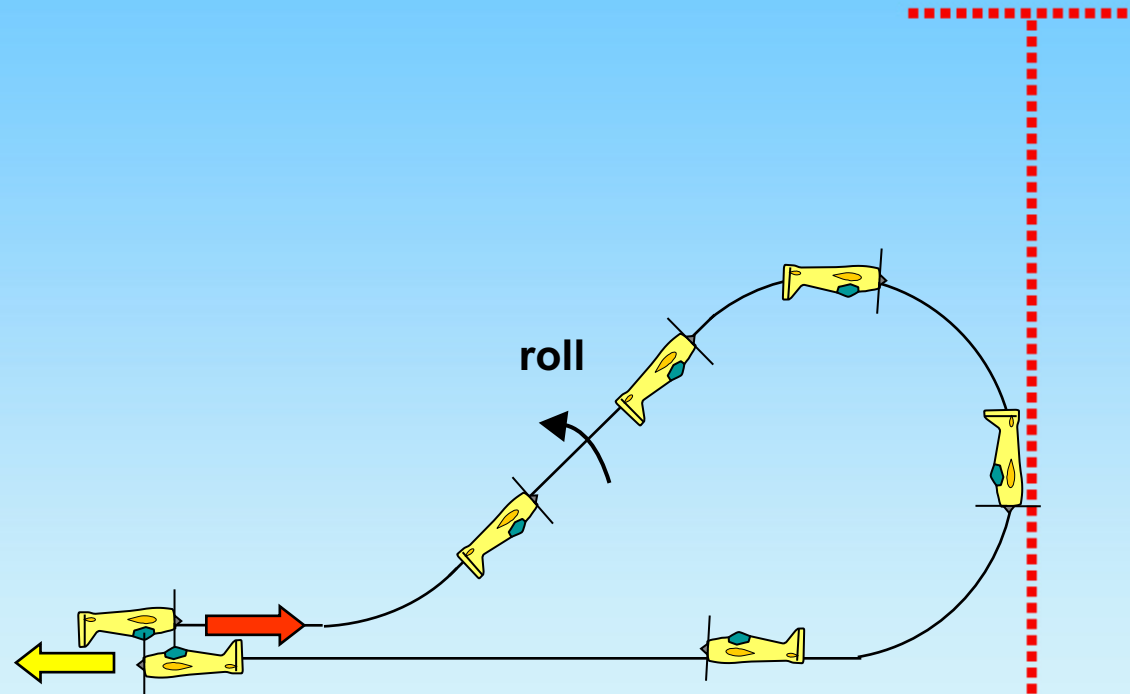

From inverted, push through a 1/8 loop into a 45° upline, perform a roll, pull through a 5/8 loop, exit upright.



# P-19.10 Half Reverse Cuban 8 with roll



Roll on middle of the line.

All radii are equal.

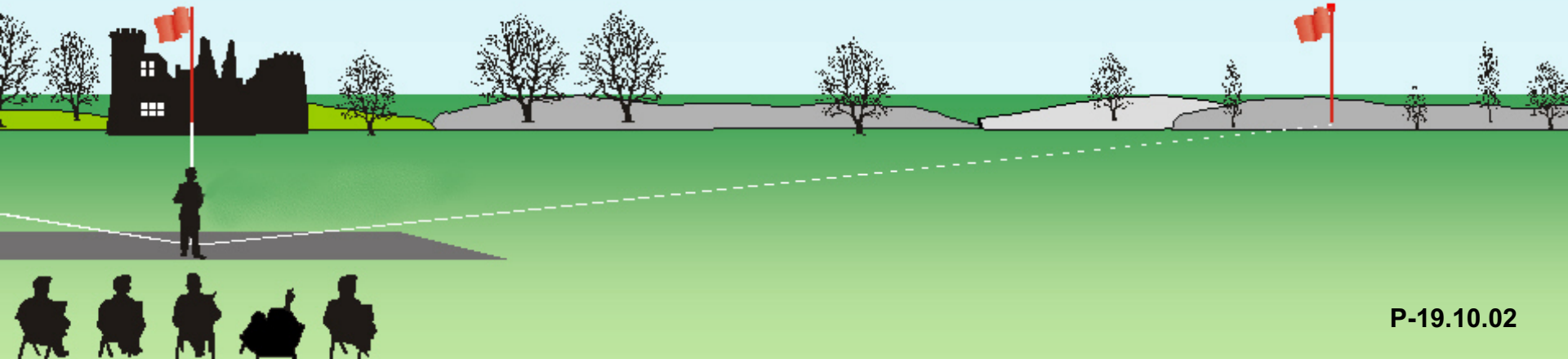
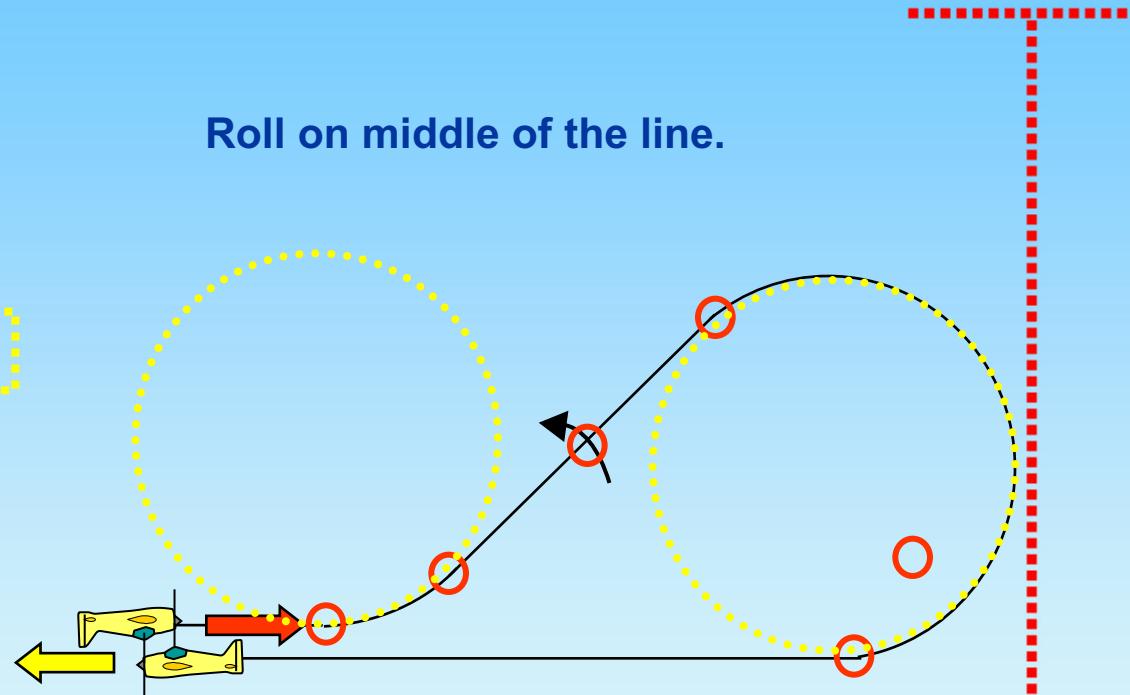

# P.19.11 Knife-Edge flight with 1 ¼ roll, 1 ¼ roll

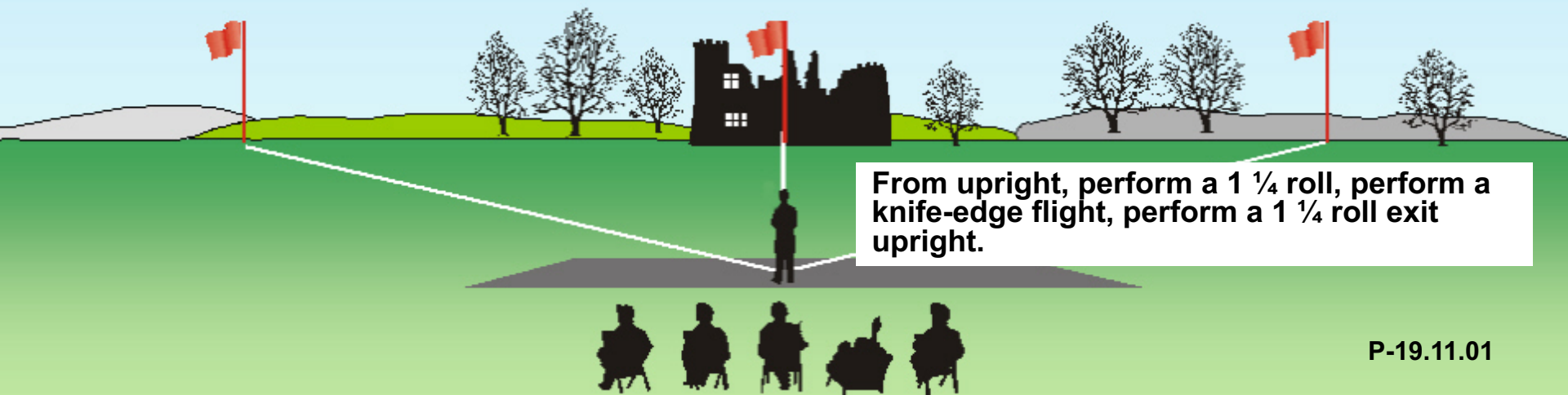
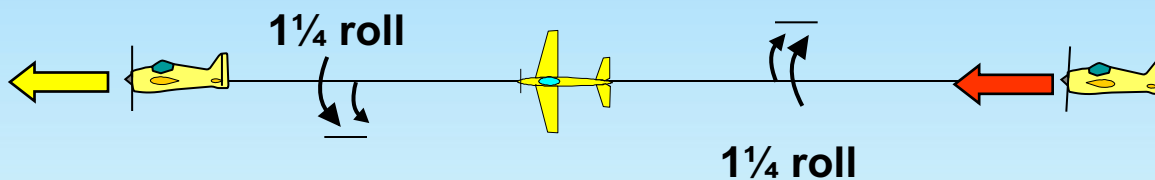

From upright, perform a 1 ¼ roll, perform a knife-edge flight, perform a 1 ¼ roll exit upright.



## P.19.11 Knife-Edge flight with 1 ¼ roll, 1 ¼ roll

During the knife edge  
the wing must be in  
the vertical plane.

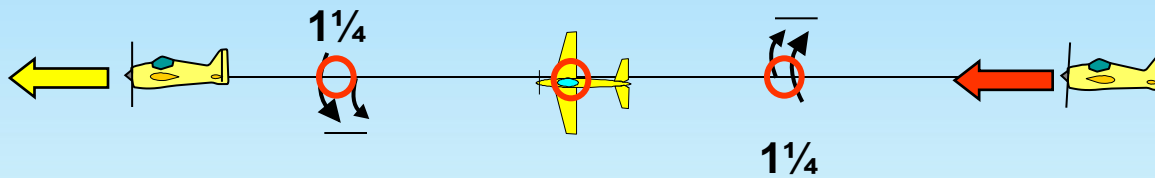

# P-19.12 Immelman Turn with $\frac{1}{2}$ roll

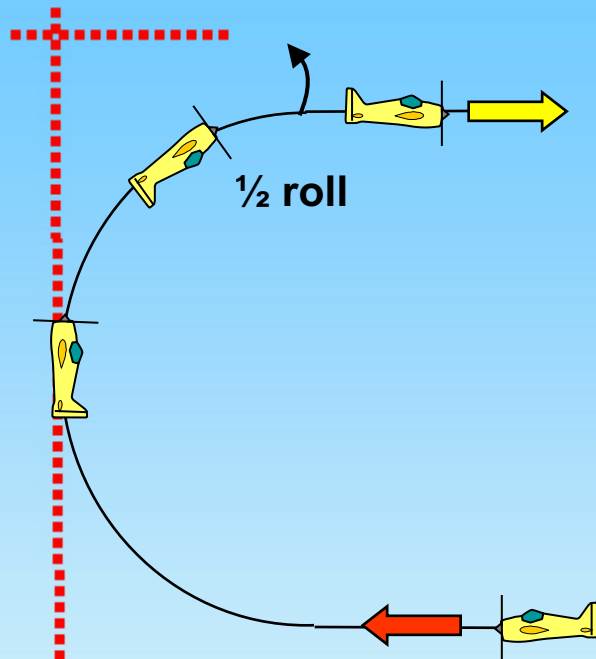

From upright, pull through a  $\frac{1}{2}$  loop, perform a  $\frac{1}{2}$  roll, exit upright.



# P-19.12 Immelman Turn with 1/2 roll

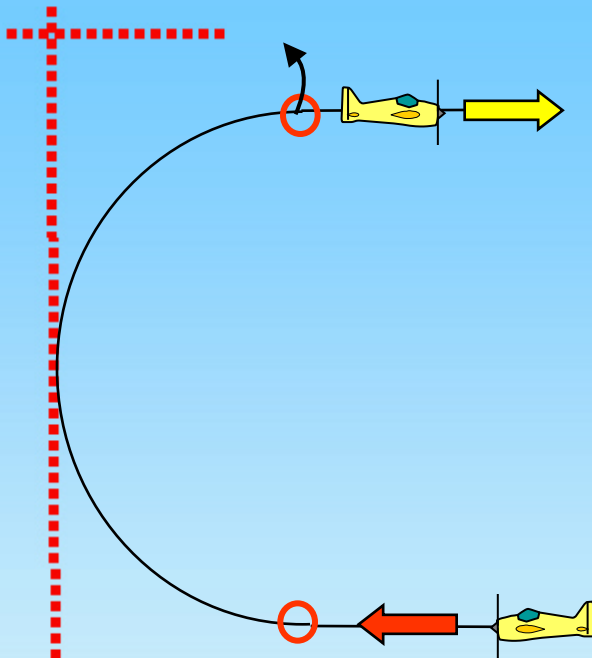

The 1/2 roll must follow immediately after the 1/2 loop.

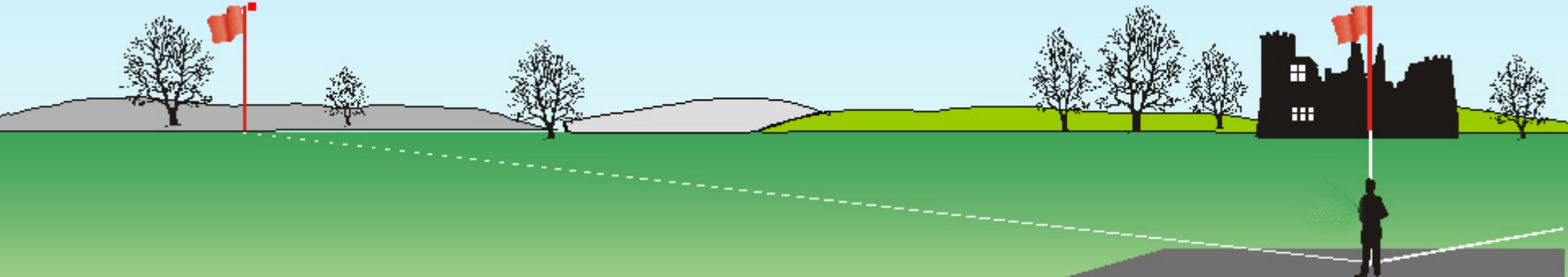

# P-19.13 Loop with two 1/2 rolls integrated

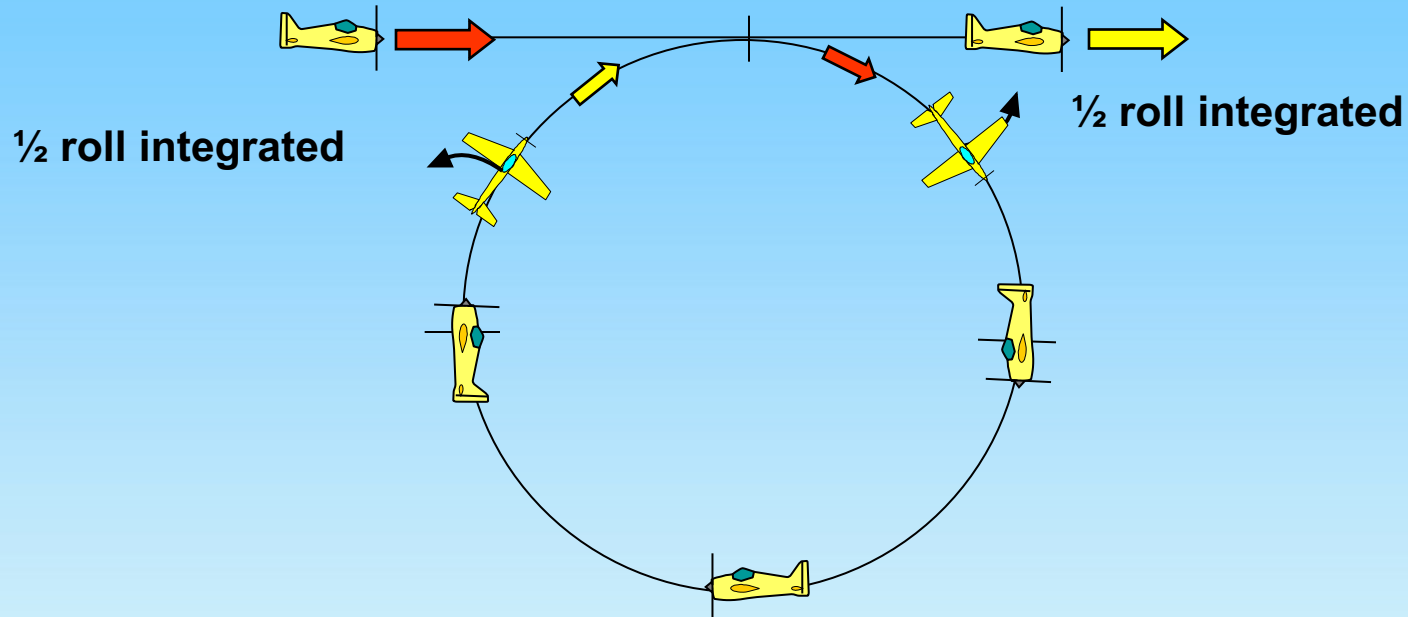

$\frac{1}{2}$  roll integrated

$\frac{1}{2}$  roll integrated

From upright, push through a loop while integrating a  $\frac{1}{2}$  roll in the first  $90^\circ$  and another  $\frac{1}{2}$  roll in the last  $90^\circ$ , exit upright.

# P-19.13 Loop with two 1/2 rolls integrated



Loop must be round.

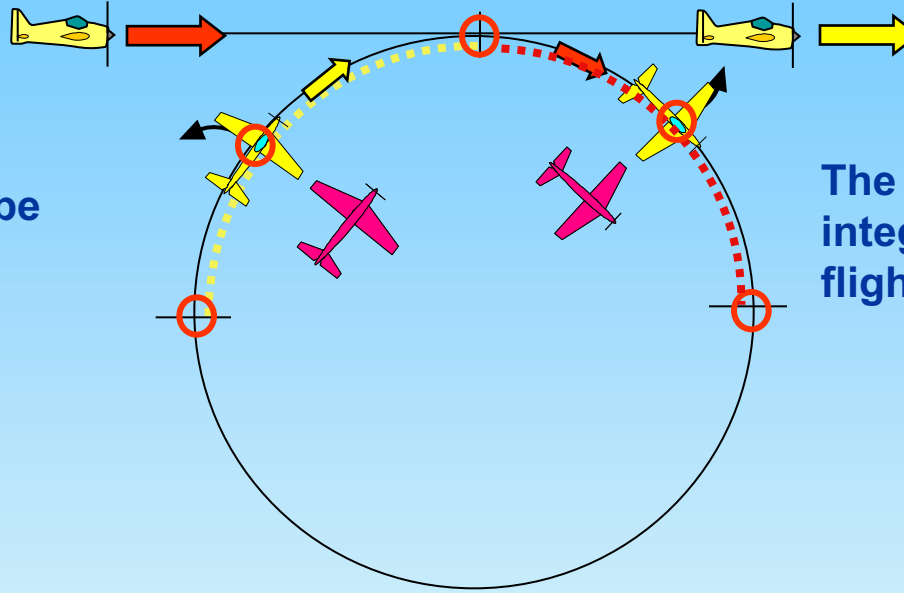

The 1/2 rolls must be integrated on circular flightpath of the loop.





# P-19.14 Half Square Loop on Corner with $\frac{1}{2}$ roll

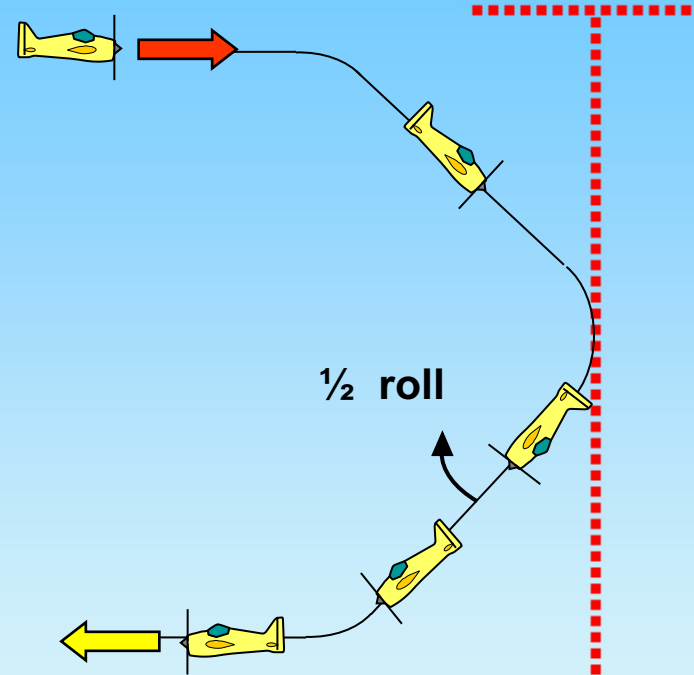

From upright, push through a  $\frac{1}{8}$  loop into a  $45^\circ$  downline, push through a  $\frac{1}{4}$  loop into a  $45^\circ$  downline, perform a  $\frac{1}{2}$  roll, pull through a  $\frac{1}{8}$  loop, exit upright.





# P-19.14 Half Square Loop on Corner with $\frac{1}{2}$ roll

$\frac{1}{2}$  roll on middle of the line.

All radii are equal.

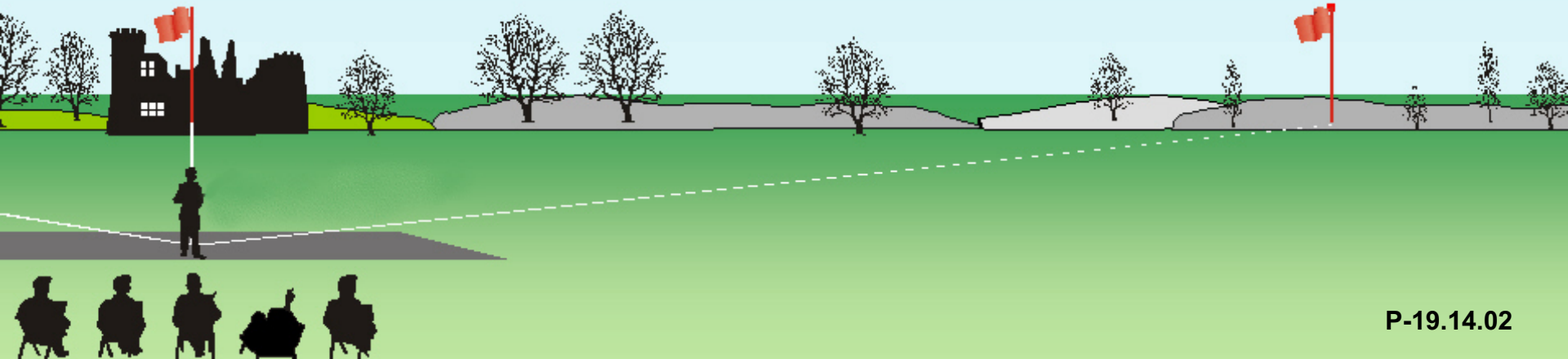
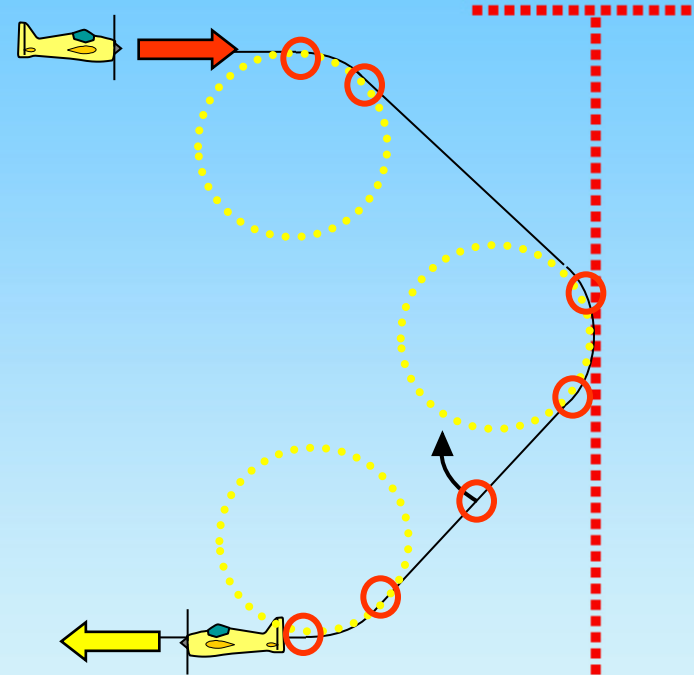



## P-19.15 Double Key with roll, $\frac{1}{2}$ roll, $\frac{1}{2}$ roll, roll

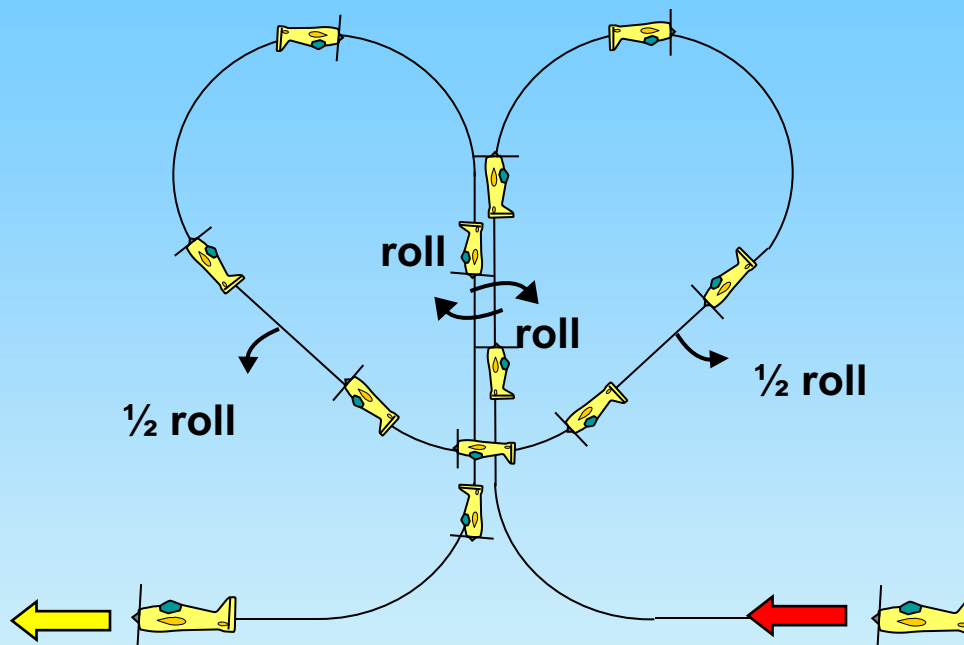

From upright, pull through a  $\frac{1}{4}$  loop into a center vertical upline, perform a roll, pull through a  $\frac{5}{8}$  loop into a  $45^\circ$  downline, perform a  $\frac{1}{2}$  roll, push through a  $\frac{1}{4}$  loop into a  $45^\circ$  upline, perform a  $\frac{1}{2}$  roll, pull through a  $\frac{5}{8}$  loop into a center vertical down-line, perform a roll, pull through a  $\frac{1}{4}$  loop, exit upright.

# P-19.15 Double Key with roll, 1/2 roll, 1/2 roll, roll

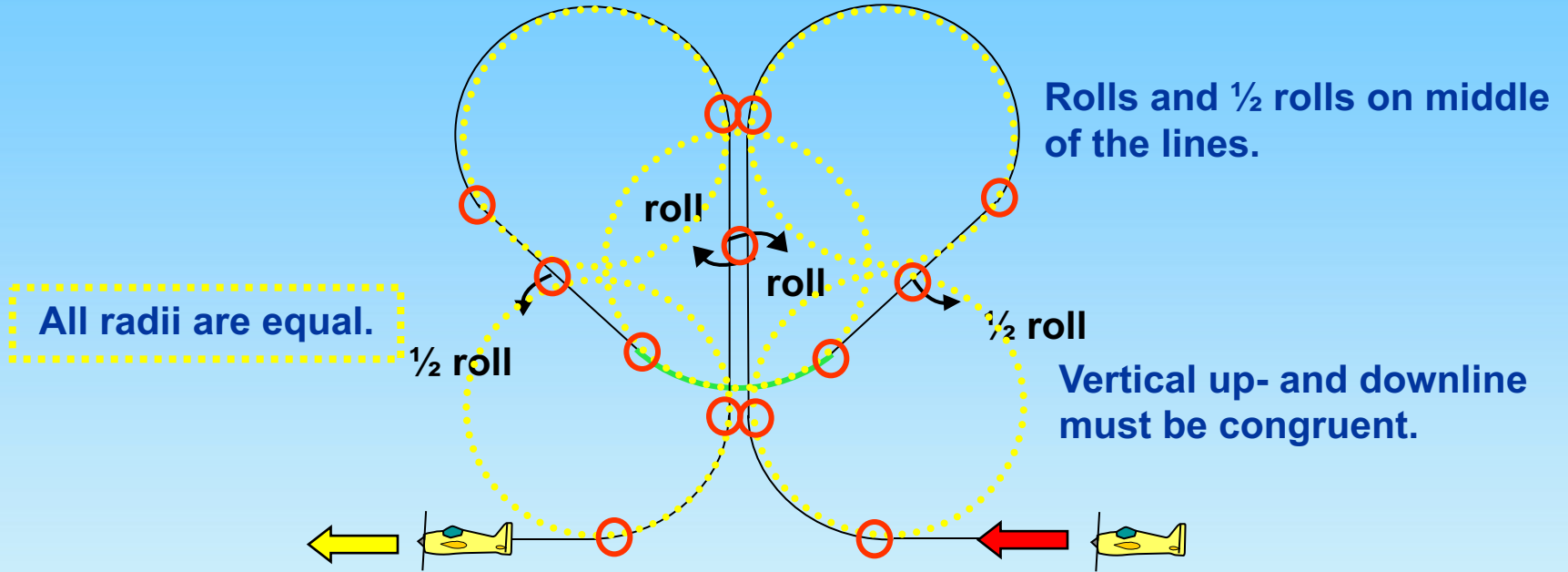

According to the manoeuvre description the manoeuvre may be flown with with different length of the center vertical up and downlines.

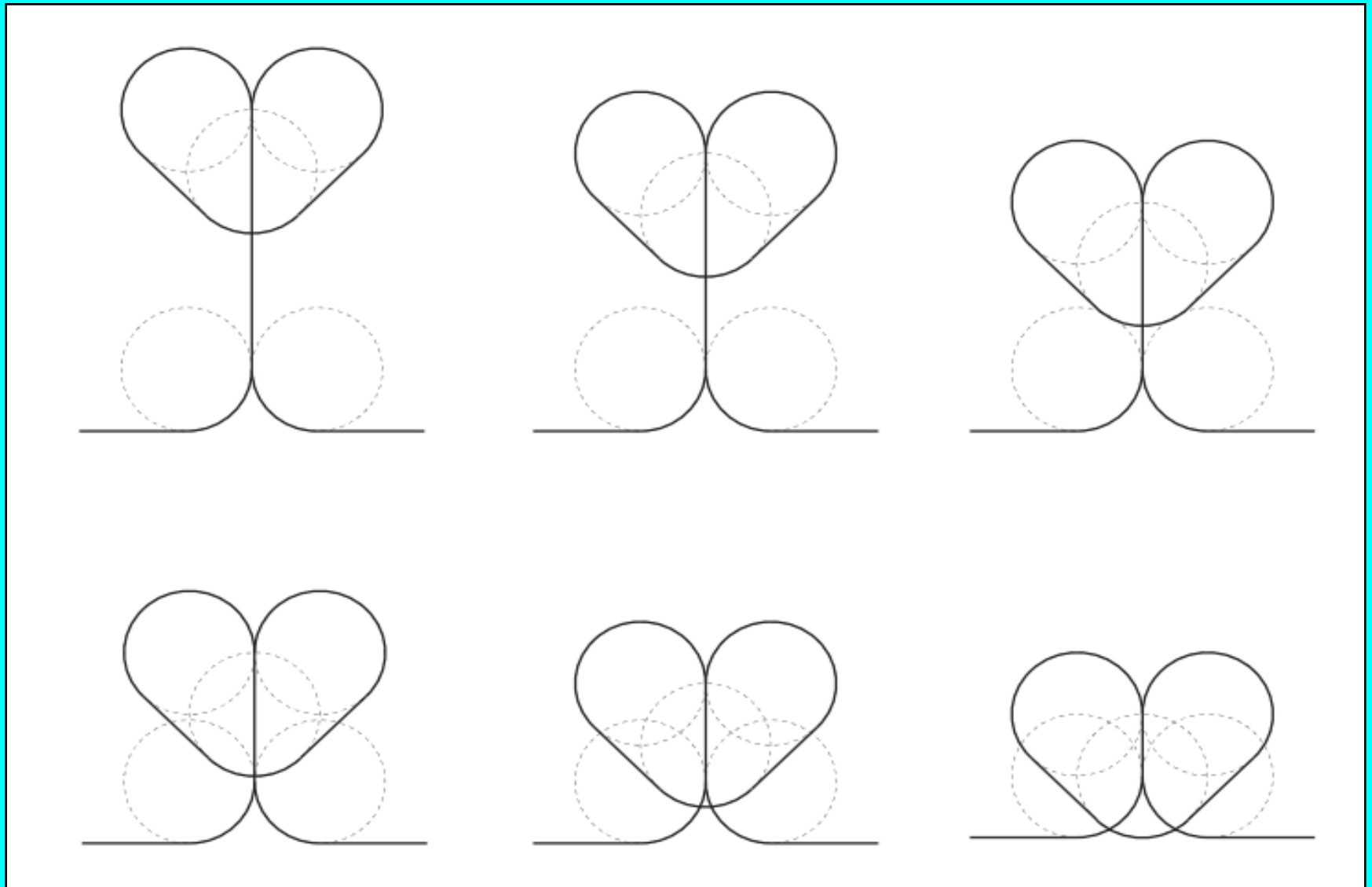

# P-19.16 Half Cuban 8 with consecutive two $\frac{1}{4}$ rolls

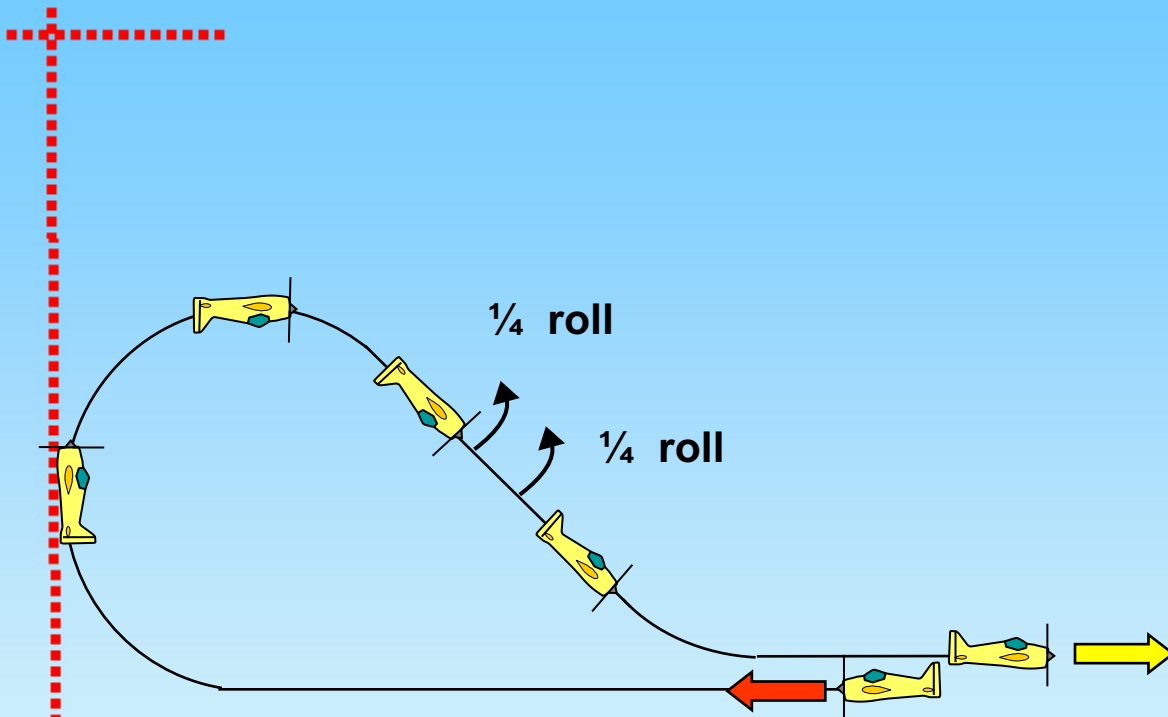

From upright, pull through a  $\frac{5}{8}$  loop into a  $45^\circ$  downline, perform consecutively two  $\frac{1}{4}$  rolls, exit upright.



# P-19.16 Half Cuban 8 with consecutive two 1/4 rolls

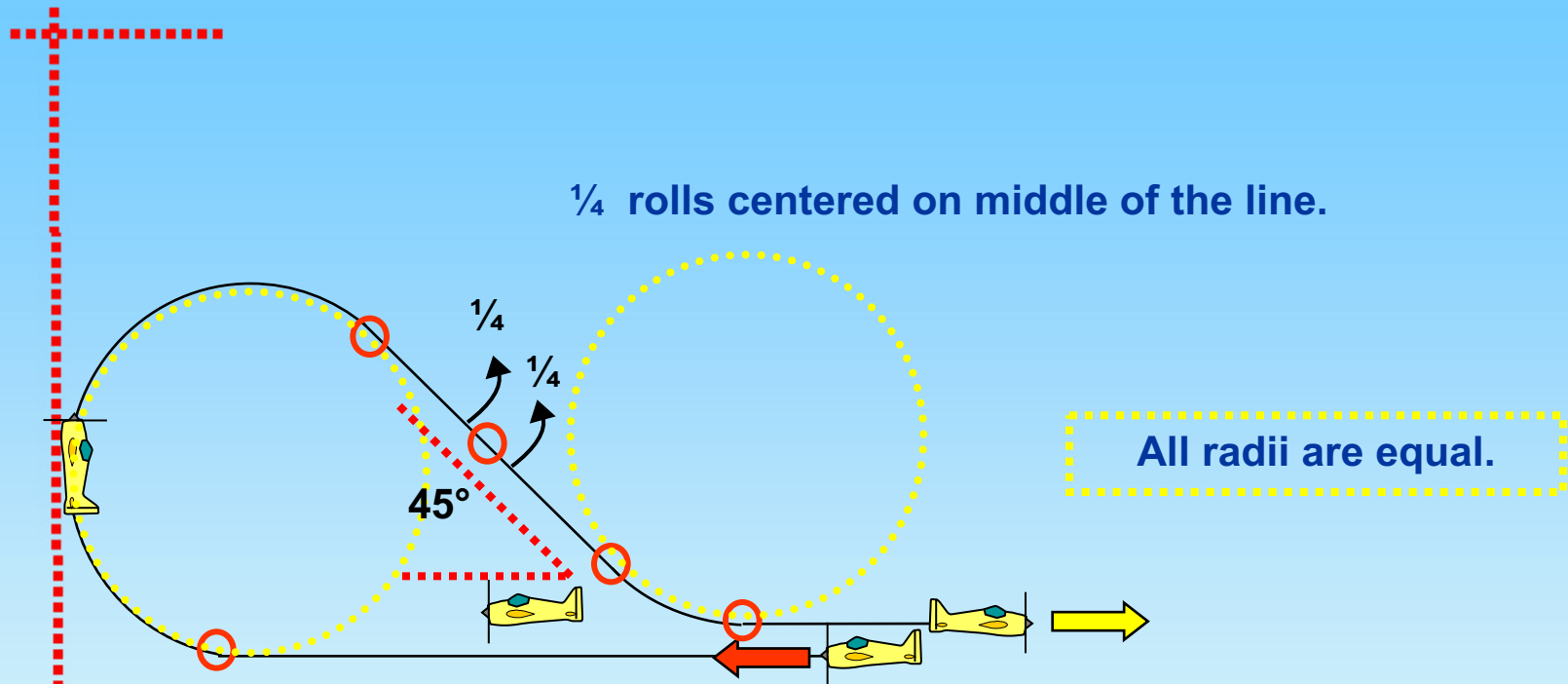

1/4 rolls centered on middle of the line.

All radii are equal.

Lines between part rolls must be short and of recognizable length.

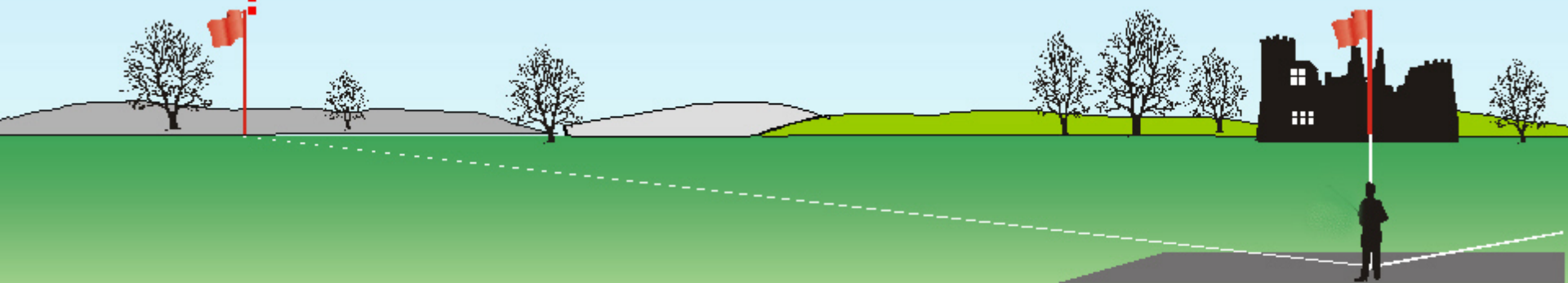



# P-19.17 Square Loop with, $\frac{1}{2}$ roll, $\frac{1}{2}$ roll, $\frac{1}{2}$ roll, $\frac{1}{2}$ roll

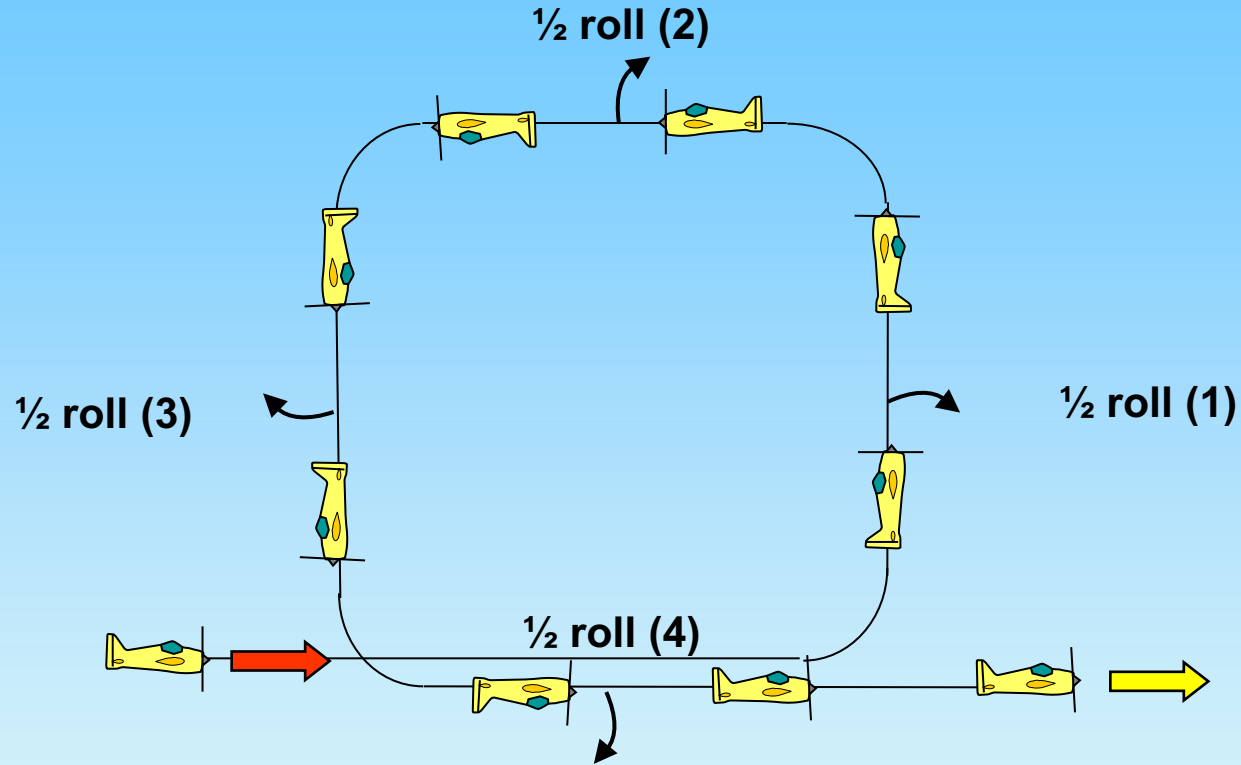

From upright perform a square loop while performing a  $\frac{1}{2}$  roll in each one leg, exit upright.



# P-19.17 Square Loop with, $\frac{1}{2}$ roll, $\frac{1}{2}$ roll, $\frac{1}{2}$ roll, $\frac{1}{2}$ roll



$\frac{1}{2}$  rolls on middle of the lines.

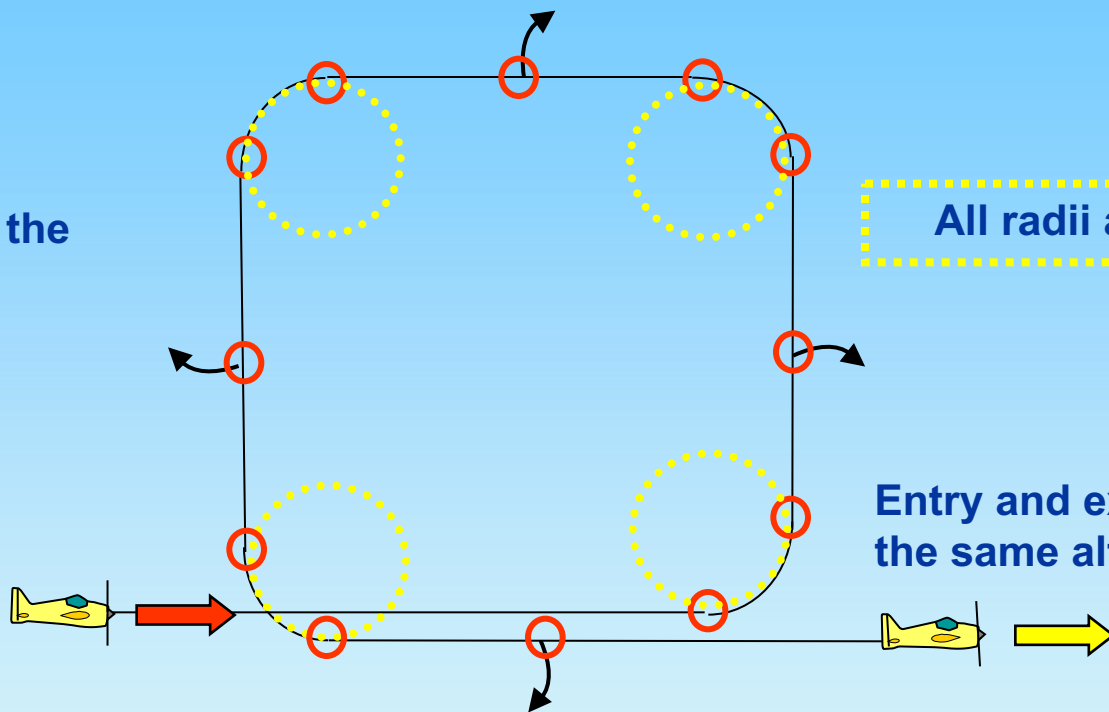

Entry and exit must be at the same altitude.







# Landing procedure ( not judged, not scored )

The direction of the landing may be different to the take off.

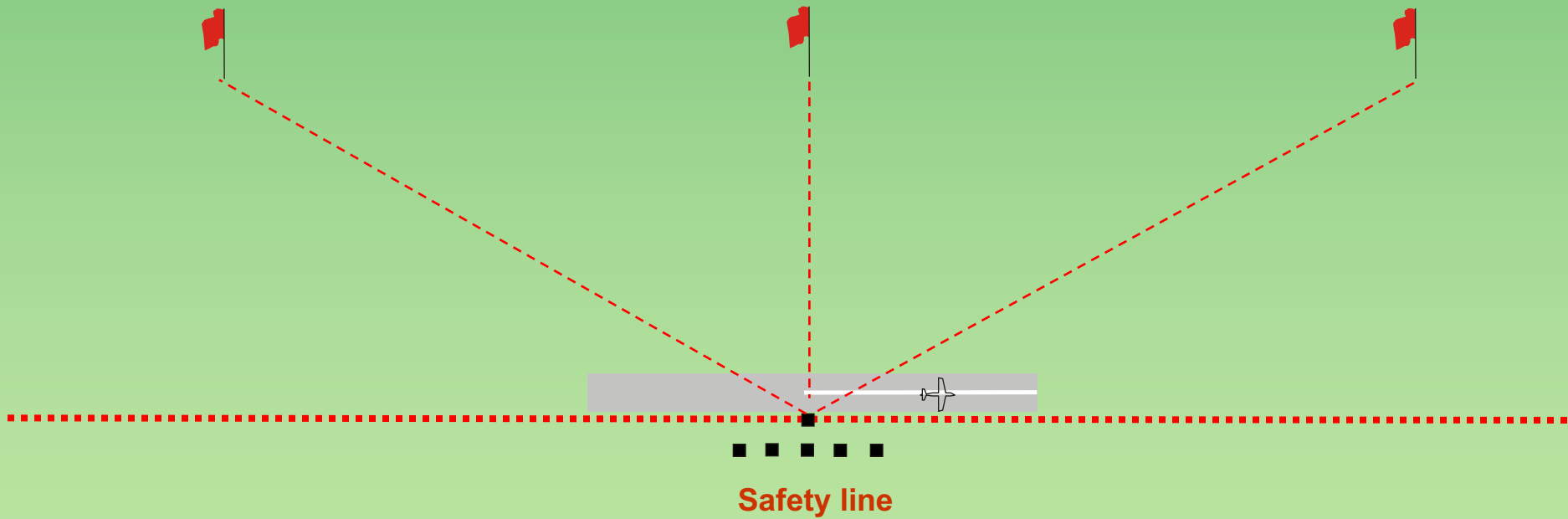

Forget **WHO** is flying  
(friend, rival, countryman, flier from other nation)

Forget **WHAT** is flying  
(2-stroke, 4-stroke, electric)

**LOOK ONLY AT LINES DESCRIBED IN THE SKY!**  
(and the precision, smoothness, positioning, and size)

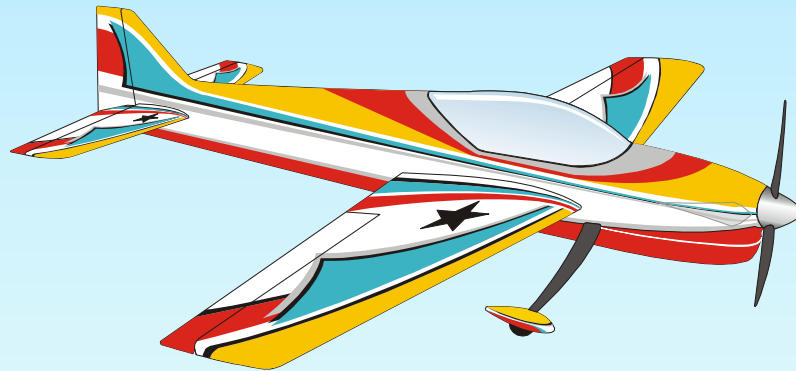

**Thank you!**

© Peter Uhlig, October 2016